

**PROJECT INFORMATION:**

OWNER/APPLICANT: DAIM LOGISTICS, INC. 128 PARK DRIVE FULTONVILLE, NY 12072

PROPERTY TAX MAP NUMBER: 52-4-3.12

PARCEL AREA: 354,053± SF / 8.13± AC

MUNICIPALITY: TOWN OF GLEN, MONTGOMERY COUNTY

ZONING: INDUSTRIAL - I WAREHOUSE

HEIGHT: REQUIRED: NO MINIMUM EXISTING: 32± FT PROPOSED: 32 FT (1 STORY)

AREA: REQUIRED: NO MINIMUM EXISTING: 10,000± SF PROPOSED: 64,000± SF

LOT COVERAGE: REQUIRED: 30% MAXIMUM EXISTING: 2.8% PROPOSED NEW: 15.2% PROPOSED TOTAL: 18.0%

WIDTH/FRONTAGE: REQUIRED: NO MINIMUM EXISTING: 1,062.95 FT

SETBACKS: REQUIRED: FRONT: 50 FT SIDE: 20/50 FT REAR: 30 FT PROPOSED: FRONT: 151.00 FT SIDE: 35 FT / 250.5 FT REAR: 31 FT

PARKING: REQUIRED STALL SIZE: 9' X 20' PROPOSED: 9' X 20'

1 SPACE PER 225 SF OF GFA OFFICE USE  
1 SPACE PER 1.5 EMPLOYEES ON LARGEST SHIFT  
2,000 SF / 225 = 8.9 ~ 9 SPACES REQUIRED, OFFICE  
10 EMPLOYEES MAX SHIFT / 1.5 = 6.7 ~ 7 SPACES

WAREHOUSE: 16 SPACES  
PROPOSED: TOTAL 37 SPACES

PROPOSED DEVELOPMENT:  
54,000 SF WAREHOUSE WITH ASSOCIATED LOADING AND PARKING  
STEEL FRAME CONSTRUCTION  
270' X 200' X 32'  
ROOF PANEL: 24 GA. GALVALUME  
WALL PANEL: 26 GA. GALVALUME

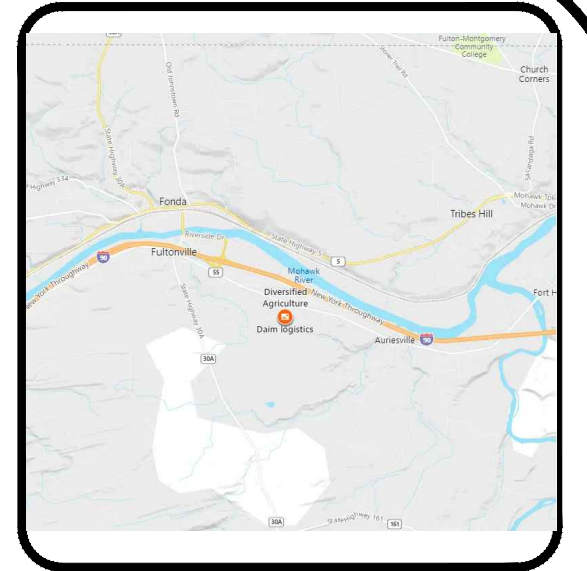

SITE LOCATION MAP  
SCALE: N.T.S.

**GENERAL NOTES:**

- ALL SURVEY INFORMATION IS REFERENCED TO:
  - MAP ENTITLED "SITE PLAN DAIM LOGISTICS, LOT 3 GLEN CANAL VIEW BUSINESS PARK" PREPARED BY ABD ENGINEERS DATED FEBRUARY 2009 AND LAST REVISED MARCH 27, 2009.
  - SURVEY UPDATE PREPARED BY GERALD R GRAY PLS, FROM A FEBRUARY 2021 FIELD SURVEY. FIELD SURVEY WAS CONDUCTED IN THE AREA OF THE PROPOSED IMPROVEMENTS. OTHER PLANIMETRIC AND UTILITY FEATURES SHOWN ARE BASED UPON MAP REFERENCE 1.
- THIS MAP IS NOT A SURVEY. INFORMATION SHOWN IS FROM MAP REFERENCES ABOVE AND FOR GENERAL INFORMATION AND DESIGN PURPOSES ONLY. A LICENSED LAND SURVEYOR SHALL STAKE OUT ANY BUILDINGS OR SEPTIC AREAS TO CONFIRM THE SETBACKS INDICATED.
- NORTH IS REFERENCED TO NAD 83 NEW YORK STATE PLANES EAST ZONE. ELEVATIONS ARE BASED ON MAP REFERENCE 1.
- SUBJECT TO ALL RIGHTS, EASEMENTS, COVENANTS OR RESTRICTIONS; RECORDED OR UNRECORDED.
- SUBJECT TO ANY STATEMENT OF FACT CONTAINED IN AN UP TO DATE TITLE REPORT OR ABSTRACT OF TITLE.
- UNDERGROUND UTILITIES IF SHOWN HEREON ARE BASED ON VISIBLE PHYSICAL EVIDENCE. THEY SHOULD BE CONSIDERED SCHEMATIC ONLY AND ARE SHOWN TO DEPICT GENERAL UTILITY CONNECTIONS RATHER THAN EXACT UNDERGROUND LOCATIONS. NO CERTIFICATION IS MADE AS TO THE ACCURACY OF THE UNDERGROUND UTILITY LOCATIONS AND OTHER UTILITIES MAY EXIST THAT ARE NOT SHOWN ON THIS MAP. CALL DIG SAFE FOR FURTHER VERIFICATION.
- DUE TO SNOW COVERED CONDITIONS AT THE TIME OF THE FIELD SURVEY, CERTAIN BOUNDARY, PLANIMETRIC AND UTILITY FEATURES MAY NOT HAVE BEEN VISIBLE. THEREFORE, ARE NOT SHOWN ON THIS MAP.

**ELECTRIC SERVICE NOTES:**

- ELECTRICAL FACILITIES EXIST WITHIN LOT 3. ALL ELECTRICAL WIRES SHOULD BE EXPOSED BY POT HOLING PRIOR TO ANY EXCAVATION.
- ELECTRIC SERVICE AND TRANSFORMER PAD (IF NECESSARY) TO BE SPECIFIED BY NATIONAL GRID PLANNERS.

**LIGHTING SCHEDULE**  
BY POINT SOURCE GROUP, OR APPROVED EQUAL  
WALL MOUNTED LIGHT  
SLEEVE & VALVE CONNECTION TO EXISTING MAIN  
FIXTURES: 9 TOTAL  
MANUFACTURER: LITHONIA LIGHTING  
CATALOG #: RSX2 LED P2 40K R3  
LUMENS: 17,202

NOTES:  
1. ALL LIGHTING SHALL BE SHIELDED AND/OR PLACED IN SUCH A MANNER AS TO PREVENT OFF-SITE ILLUMINATION.

BORING LOG		
	PROFILE	STABILIZED INFILTRATION RATE
B-1	0-1' TOPSOIL 1'-6.8' SILTY SAND (GROUNDWATER OBSERVED AT 6.4') 6.8'-8.6' POORLY GRADED SAND 8.6'-20' GLACIAL TILL-SILTY SAND W/GRAVEL 20'-21.5' SILTY SAND	
B-2	0-1' TOPSOIL 1'-1.5' FILL-SILTY SAND 1.5'-8' GLACIAL TILL-POORLY GRADED SAND W/SILT (GROUNDWATER OBSERVED AT 4.5') 8'-21.5' GLACIAL TILL-SILTY SAND W/GRAVEL	
B-3	0-3' TOPSOIL 0.3'-12.6' GLACIAL TILL-SILTY SAND W/GRAVEL (NO GROUNDWATER OBSERVED)	
B-4	0-1' TOPSOIL 1'-21.5' GLACIAL TILL-SILTY SAND W/GRAVEL (GROUNDWATER OBSERVED AT 2')	
B-5	0-1' TOPSOIL 1'-2' SILTY SAND 2'-10.4' GLACIAL TILL-SILTY SAND W/GRAVEL (NO GROUNDWATER OBSERVED)	
BORINGS PERFORMED ON 04/28/21 & 04/09/21 BY TERRACON.		
IT 1	PERFORMED AT 18" DEPTH	STABILIZED RATE 15 MIN/IN
IT 2	PERFORMED AT 18" DEPTH	STABILIZED RATE 20 MIN/IN
INFILTRATION TESTS PERFORMED BY C. LONGO 10/14/21		

No.	Revision Description	Date
1	ADDED PROPOSED LAND CONVEYANCE	3/8/21
2	UPDATED SURVEY AND BUILDING LAYOUT	4/1/21
3	PRELIMINARY GRADING & DRAINAGE DESIGN	8/19/21
4	FULL PLAN SET	10/20/21
5	MISC. REVISIONS	11/3/21
6	REVISIONS PER TDE	12/9/21
7	REVISIONS PER TDE	12/30/21

PRIOR TO ANY EARTH DISTURBANCE THE CONTRACTOR SHALL CALL IN A TICKET TO DIG SAFE NY AND OBTAIN A CLEAR TO DIG

IT IS A VIOLATION OF SECTION 7209 OF THE NYS EDUCATION LAW FOR ANY PERSON TO ALTER ANY ITEM ON THIS PLAN IN ANY WAY UNLESS HE/SHE IS ACTING UNDER THE DIRECT SUPERVISION OF A PROFESSIONAL ENGINEER.

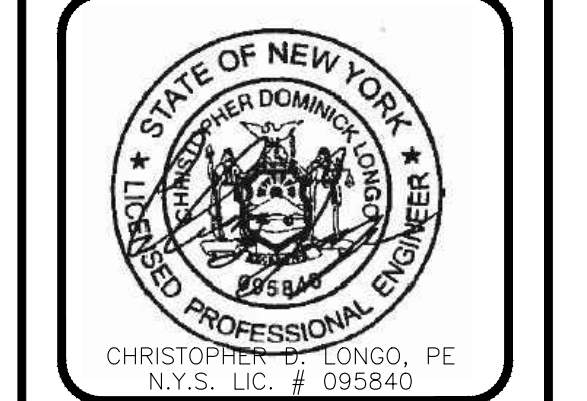

EMPIRE ENGINEERING, PLLC  
1900 DUANESBURG ROAD  
DUANESBURG, NY 12056  
PH: (518) 858-4117  
EMAIL: CLONGO@EMPIREENG.NET

PROJECT: SITE PLAN AMENDMENT DAIM LOGISTICS, INC.  
128 PARK DRIVE  
GLEN PARK  
FULTONVILLE, NY 12072

The SITE LAYOUT, GRADING & UTILITIES PLAN

Date: 02/12/2021  
Scale: 1"=40'  
Job#: 21004  
Sheet 1 of 5

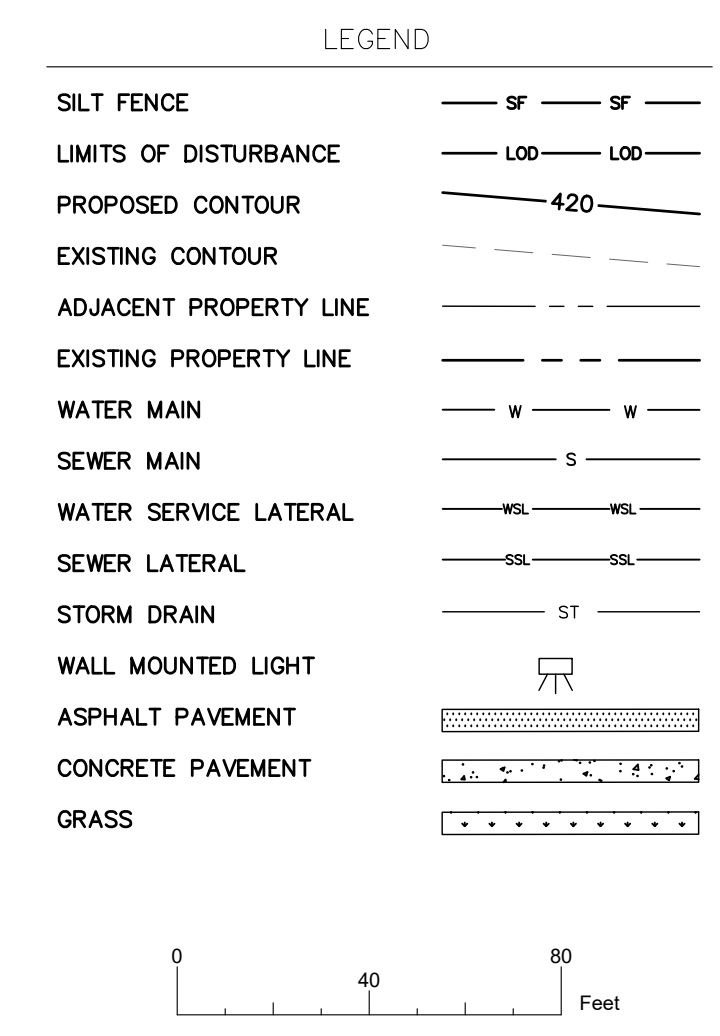

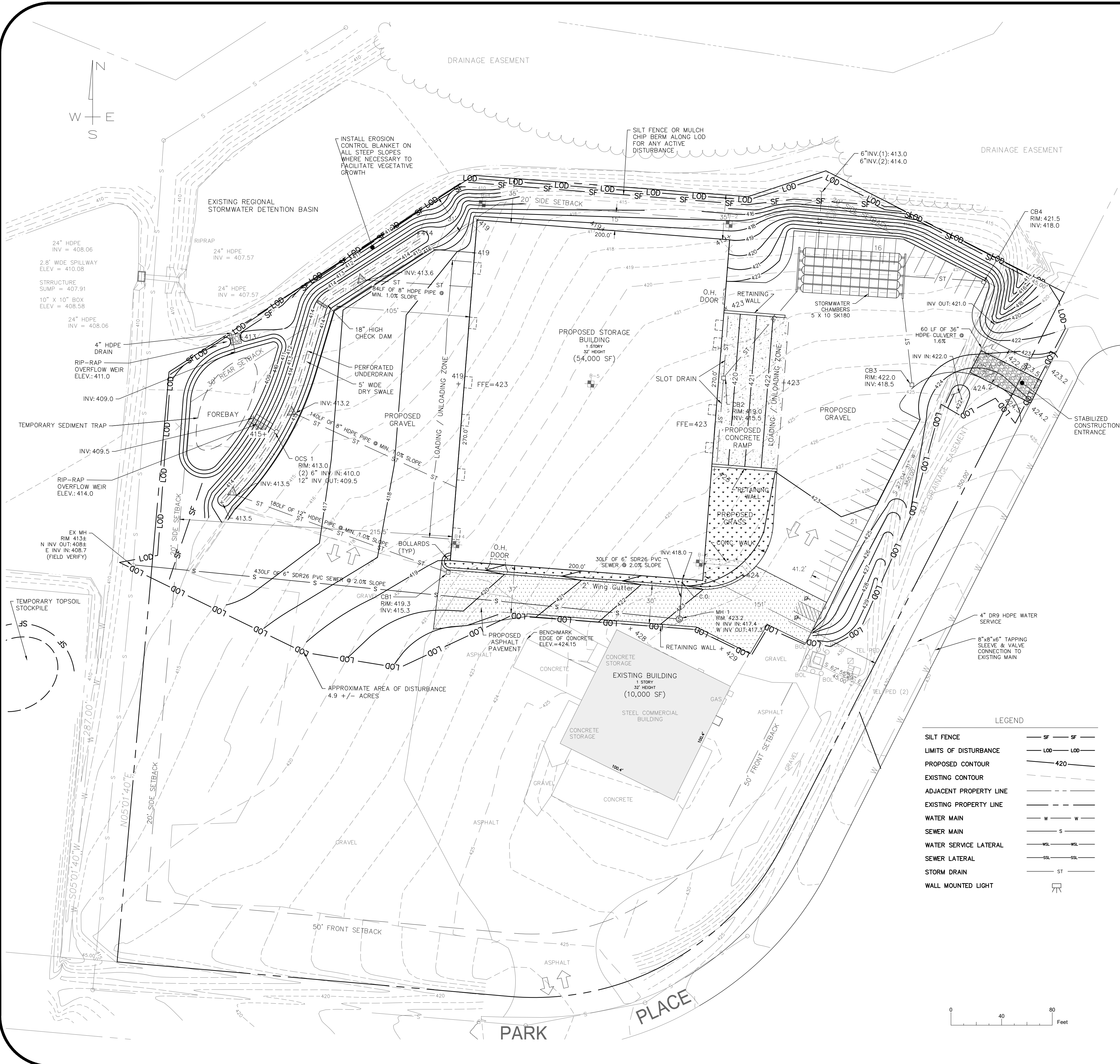

**EROSION & SEDIMENT CONTROL GENERAL NOTES:**

1. THIS PROJECT QUALIFIES FOR COVERAGE UNDER THE NYSDEC GENERAL PERMIT GP 0-15-002. A NOTICE OF INTENT (NOI) MUST BE FILED WITH THE NEW YORK STATE DEPARTMENT OF ENVIRONMENTAL CONSERVATION AND AUTHORIZATION RECEIVED PRIOR TO CONSTRUCTION ACTIVITIES.
2. A STORMWATER POLLUTION PREVENTION PLAN HAS BEEN PREPARED IN ACCORDANCE WITH THE NEW YORK STATE DEPARTMENT OF ENVIRONMENTAL CONSERVATION SPDES GENERAL PERMIT FOR STORMWATER DISCHARGES GP 0-15-002 AND SHALL BE CONSIDERED SUPPLEMENTAL TO THESE PLANS.
3. ANY CONTRACTOR INVOLVED IN ANY EARTHWORK ACTIVITY SHALL REVIEW ALL PLANS AND PERMIT CONDITIONS AND CERTIFY ACKNOWLEDGEMENT IN WRITING. IT IS THE CONTRACTOR'S RESPONSIBILITY TO IMPLEMENT ALL EROSION CONTROLS DESCRIBED IN GP 0-15-002, AND IT IS NOT THE INTENT OF THESE DRAWINGS TO REPLACE OR DISSEMINATE THE PERMIT REQUIREMENTS. THE CONTRACTOR SHALL REMAIN IN COMPLIANCE WITH THE PERMIT AT ALL TIMES.
4. NO MORE THAN FIVE (5) ACRES OF SITE SHALL BE DISTURBED AT ONE TIME. THE CONTRACTOR SHALL COORDINATE EARTHWORK ACTIVITIES AND IMPLEMENTATION OF SOIL STABILIZATION MEASURES TO ENSURE COMPLIANCE WITH THIS REQUIREMENT.
5. DISTURBED AREAS SHALL NOT BE LEFT UNSTABILIZED FOR MORE THAN 14 DAYS AFTER COMPLETION OR SUSPENSION OF GRADING OPERATIONS.
6. EROSION AND SEDIMENT CONTROL MEASURES SHALL BE IMPLEMENTED IN ACCORDANCE WITH THE LATEST EDITION OF NEW YORK STANDARDS AND SPECIFICATIONS FOR EROSION AND SEDIMENT CONTROL" (aka: THE BLUE BOOK) EROSION CONTROL DEVICES SHALL BE INSTALLED PRIOR TO ANY CONSTRUCTION ACTIVITIES.
7. EROSION CONTROL DEVICES SHALL NOT BE REMOVED UNTIL THE TOWN ENGINEER HAS APPROVED FINAL STABILIZATION.
8. SILT FENCE AND OTHER EROSION CONTROL DEVICES SHALL BE INSTALLED AND MAINTAINED IN ACCORDANCE WITH THESE DETAIL SHEETS AND SECTION 7A OF THE BLUE BOOK.
9. PRIOR TO ANY CONSTRUCTION ACTIVITY, THE STABILIZED CONSTRUCTION ENTRANCES SHALL BE INSTALLED.

**TEMPORARY EROSION AND SEDIMENT CONTROL NOTES:**

1. IT IS THE INTENT OF THESE PLANS AND NOTES TO BE USED AS A GUIDE BY THE CONTRACTOR TO ENSURE THAT NO ERODED MATERIAL MIGRATES FROM THE SITE OR ENTERS ANY WATER COURSE. IT IS THE CONTRACTOR'S RESPONSIBILITY TO ENSURE THAT THIS GOAL IS MET, BY IMPLEMENTING THESE PLANS AND ANY ADDITIONAL MEANS THAT MAY BE NECESSARY. FURTHER MEASURES MAY BE REQUIRED BY THE CITY, VILLAGE, OR TOWN ENGINEER. WHILE MANY OF THE EROSION CONTROL DETAILS CONTAINED WITHIN THESE PLANS ARE TAKEN DIRECTLY FROM THE BLUE BOOK, THE CONTRACTOR SHOULD CONSIDER ANY OF THE DETAILS CONTAINED IN SECTION 7A OF THE BLUE BOOK AS ACCEPTABLE PRACTICE IN THE APPROPRIATE APPLICATION.
2. THE OWNER/OPERATOR SHALL INSPECT AND MAINTAIN EROSION CONTROL MEASURES DAILY AND AFTER EACH RAINFALL EVENT THROUGH THE ENTIRE DEVELOPMENT PROCESS. TO ASSURE PROPER FUNCTION, SILTATION BARRIERS SHALL BE MAINTAINED IN GOOD CONDITION AND REINFORCED, EXTENDED, REPAIRED, RE-SEEDED AND PROTECTED FROM FURTHER EROSION. ALL SEDIMENT ACCUMULATED SHALL BE REMOVED AND CONTAINED IN APPROPRIATE SPOIL AREAS. WATER SHALL BE APPLIED TO NEWLY SEEDED AREAS AS NEEDED UNTIL GRASS COVER IS WELL ESTABLISHED. DURING THESE PERIODIC INSPECTIONS, THE FOLLOWING ITEMS SHOULD BE PAID PARTICULAR ATTENTION: A. SILT FENCING SHALL BE INSPECTED FOR UNDERMINING AND DETERIORATION. B. SEEDED/MULCHED AREAS SHALL BE INSPECTED TO SEE THAT A GOOD STAND IS MAINTAINED. AREAS SHALL BE REPAIRED AS NECESSARY.
3. PRIOR TO ANY CONSTRUCTION ACTIVITY, THE STABILIZED CONSTRUCTION ENTRANCES SHALL BE INSTALLED.
4. SILT FENCE AND OTHER EROSION CONTROL DEVICES SHALL BE INSTALLED AND MAINTAINED IN ACCORDANCE WITH THESE DETAIL SHEETS AND SECTION 7A OF THE BLUE BOOK. SILT FENCING SHALL BE INSTALLED AT THE PERIMETER OF ALL SLOPES TO BE GRADED, PRIOR TO GRADING OPERATIONS.
5. CLEARING OPERATIONS SHALL BE LIMITED TO ACTIVE WORK AREAS.
6. CARE SHALL BE TAKEN TO PRESERVE AS MUCH EXISTING VEGETATION AS POSSIBLE AND HEALTHY TREES OF DESIRABLE SPECIES SHALL BE PROTECTED.
7. CONSTRUCTION TRAFFIC SHALL NOT CROSS STREAMS OR DITCHES EXCEPT AT SUITABLE CROSSING FACILITIES. EQUIPMENT SHALL NOT OPERATE, UNNECESSARILY, WITHIN WATERWAYS OR DRAINAGE DITCHES.
8. EXISTING PAVEMENT AREAS SHALL BE CLEANED AT THE DIRECTION OF THE CITY, VILLAGE, OR TOWN ENGINEER.
9. WATER TRUCKS SHALL BE USED TO MINIMIZE DUST POLLUTION ON SITE, AND ON ADJACENT ROADWAY AREAS AS DIRECTED BY THE CITY, VILLAGE, OR TOWN ENGINEER.
10. ANY WATER PUMPED AS A RESULT OF DEWATERING ACTIVITIES SHALL BE PUMPED INTO A DEWATERING PIT.
11. ALL AREAS DISTURBED IN THE CONSTRUCTION PROCESS SHALL BE STABILIZED WITH SEED AND MULCH NO MORE THAN 14 DAYS AFTER THE COMPLETION OF WORK IN SUCH AREA. IT MAY BE NECESSARY TO SEED AND MULCH SOME AREAS SEVERAL TIMES TO MEET THIS REQUIREMENT.
12. ALL EROSION CONTROL DEVICES SHALL BE PLACED IN THE ENTIRE PHASE AS SHOWN ON THE EROSION CONTROL PLAN PRIOR TO ANY WORK ON SUCH PHASE.
13. STOCK PILES SHALL BE PROTECTED BY SILT FENCE AND SEEDED PER GP 0-15-002. THESE DEVICES SHALL BE MAINTAINED IN GOOD CONDITION UNTIL SAID STOCK PILES ARE REMOVED AND AREAS ARE PERMANENTLY STABILIZED.
14. WHEN RUNOFF IS COLLECTED AND FLOW IS CONCENTRATED IN A SWALE OR DRAINAGE DITCH, THEN CHECK DAMS SHALL BE INSTALLED TO REDUCE VELOCITY UNTIL THE SWALE AND THE AREA DRAINING TO THE SWALE ARE STABILIZED. SEDIMENT SHALL BE REMOVED FROM THE DAM AS NEEDED TO ALLOW THE CHANNEL TO DRAIN THROUGH THE DAM AND PREVENT LARGE FLOWS FROM CARRYING SEDIMENT OVER THE DAM.
15. IN NO CASE SHALL ERODIBLE MATERIALS BE STOCKPILED WITHIN 25 FEET OF ANY DITCH, STREAM OR OTHER SURFACE WATER BODY.
16. THE CONTRACTOR SHALL MAINTAIN A CLEAN CONSTRUCTION AND EQUIPMENT ENTRANCE WHENEVER PRACTICABLE.
17. EROSION CONTROL DEVICES SHALL NOT BE REMOVED UNTIL THE CITY, VILLAGE OR TOWN ENGINEER HAS APPROVED FINAL STABILIZATION.

Date	Revision	Description
11/3/21	1	MISC. REVISIONS
12/29/21	2	REVISIONS PER TIDE

PRIOR TO ANY EARTH DISTURBANCE THE CONTRACTOR SHALL CALL IN A TICKET TO DIG SAFE NY AND OBTAIN A CLEAR TO DIG

IT IS A VIOLATION OF SECTION 7209 OF THE NYS EDUCATION LAW FOR ANY PERSON TO ALTER ANY ITEM ON THIS PLAN IN ANY WAY UNLESS HE/SHE IS ACTING UNDER THE DIRECT SUPERVISION OF A PROFESSIONAL ENGINEER.

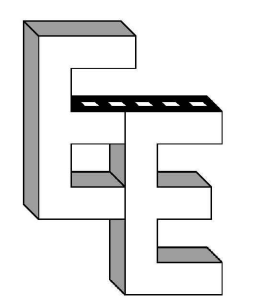

EMPIRE ENGINEERING, PLLC  
1900 DUANESBURG ROAD  
DUANESBURG, NY 12056  
PH: (518) 858-4117  
EMAIL: CLONGO@EMPIREENG.NET

PROJECT  
DAIM LOGISTICS, INC.  
128 PARK DRIVE  
GLEN PARK  
FULTONVILLE, NY 12072

The EROSION & SEDIMENT CONTROL PLAN  
Date: 10/20/2021 Sheet  
Scale: 1"=40' C102  
Job#: 21004 Sheet 2 OF 5

**LEGEND**

SILT FENCE	— SF — SF —
LIMITS OF DISTURBANCE	— LOD — LOD —
PROPOSED CONTOUR	— 420 —
EXISTING CONTOUR	— 420 —
ADJACENT PROPERTY LINE	— — — — —
EXISTING PROPERTY LINE	— — — — —
WATER MAIN	— W — W —
SEWER MAIN	— S — S —
WATER SERVICE LATERAL	— WSL — WSL —
SEWER LATERAL	— SSL — SSL —
STORM DRAIN	— ST — ST —
WALL MOUNTED LIGHT	⊠

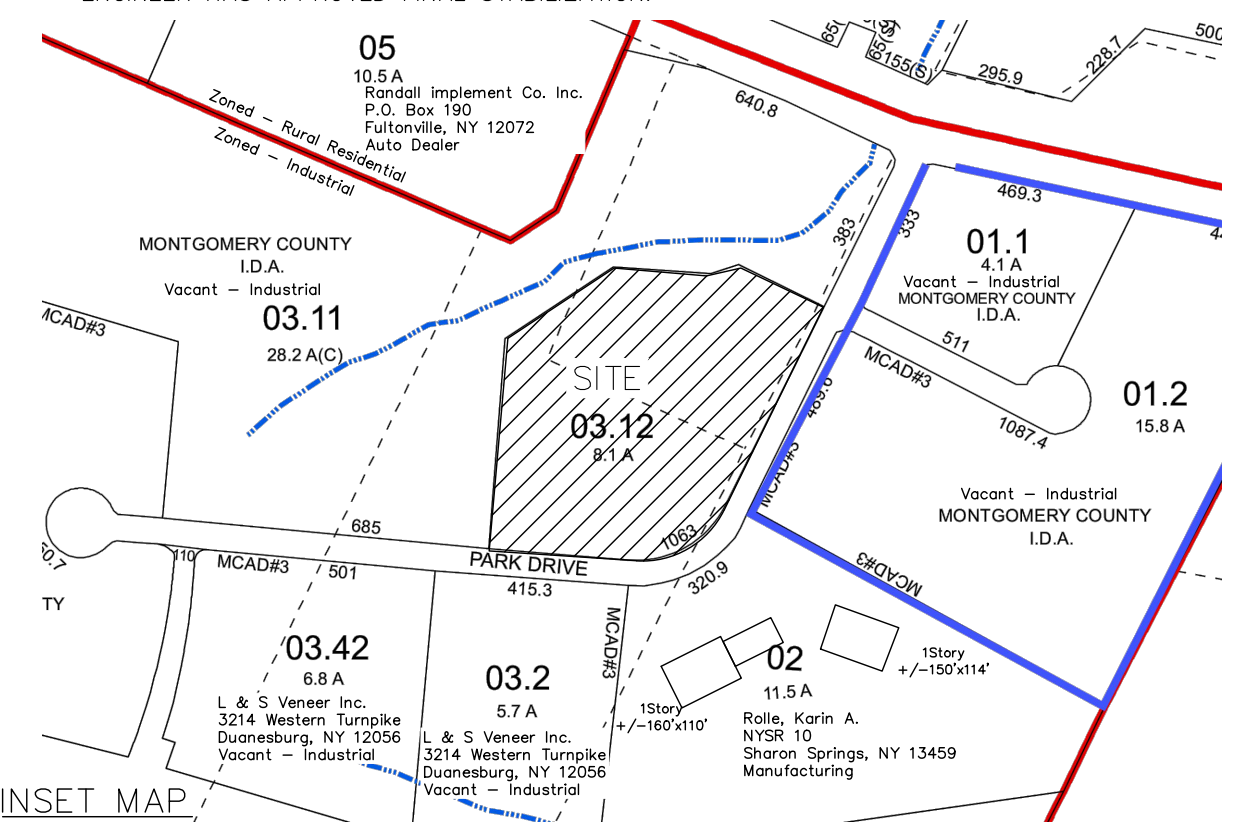

INSET MAP  
TOWN OF GLEN TAX MAP  
MONTGOMERY COUNTY NY  
SECT. 52.0-4

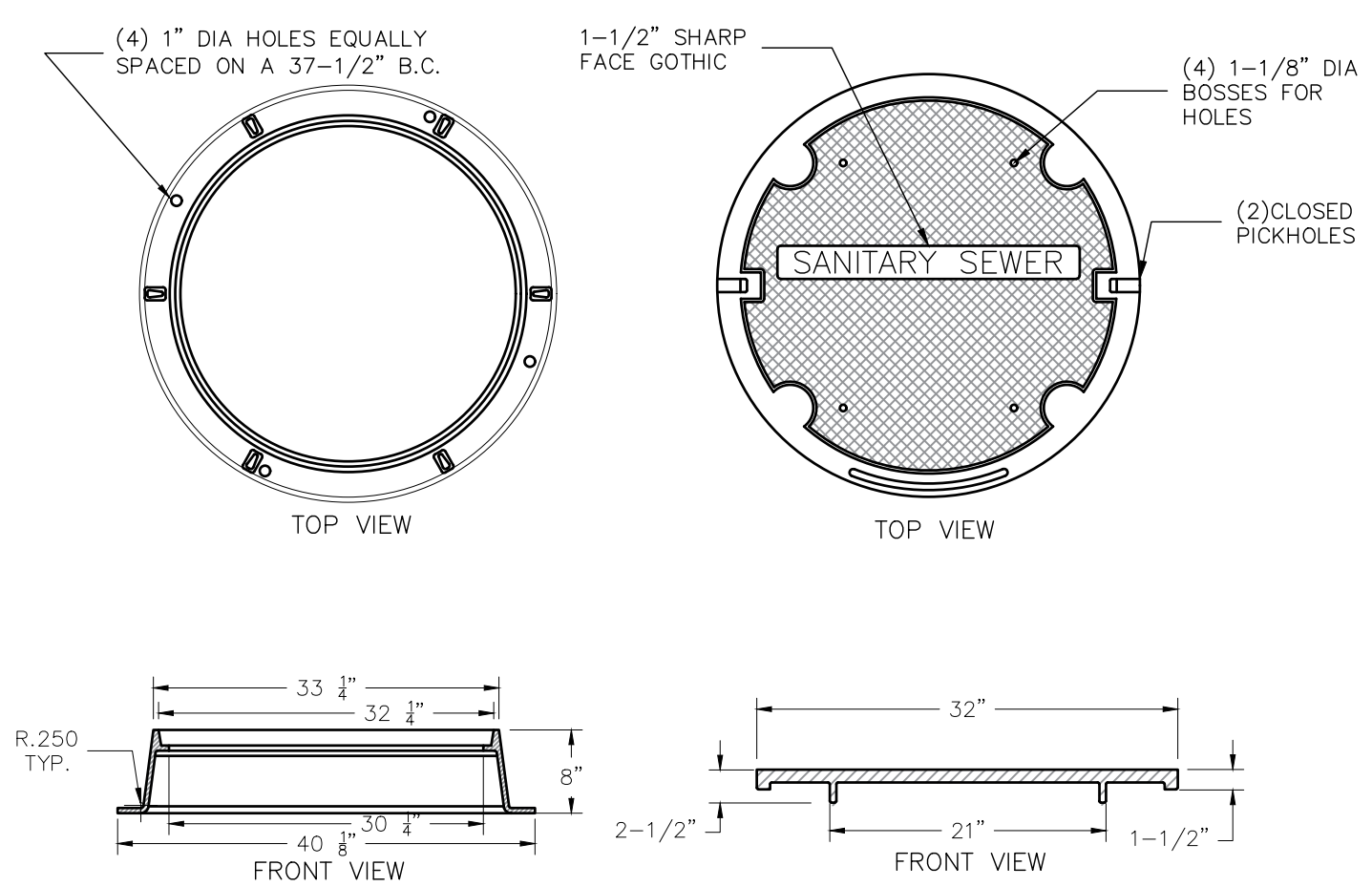

**NOTES**  
1. BY EJ PRESCOTT MODEL: C-29/62091 600. OR APPROVED EQUAL

**1** TYP. MANHOLE FRAME AND COVER  
**501**

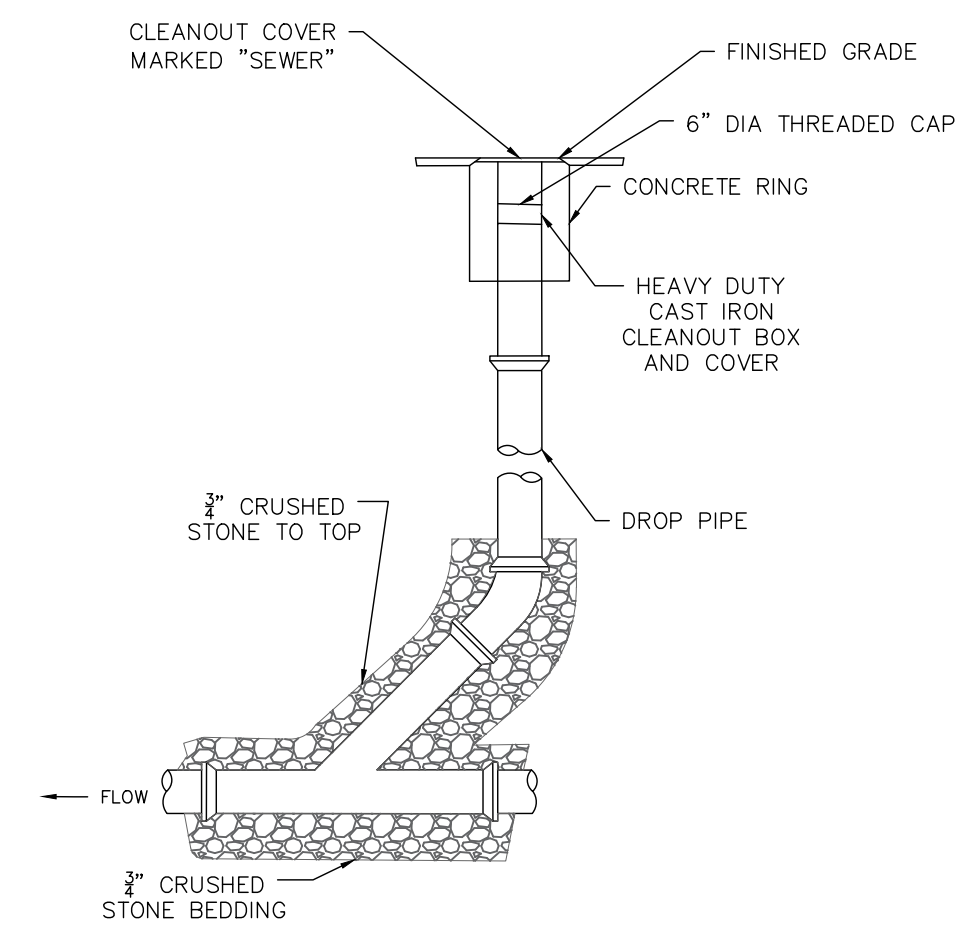

**NOTES**  
1. CLEANOUTS TO BE INSTALLED WHERE INDICATED ON THE PLANS  
2. CLEANOUT PIPE TO BE THE SAME SIZE AND MATERIAL AS SEWER/DRAIN LINE UP TO 8"

**2** SEWER CLEANOUT DETAIL  
**501** NOT TO SCALE

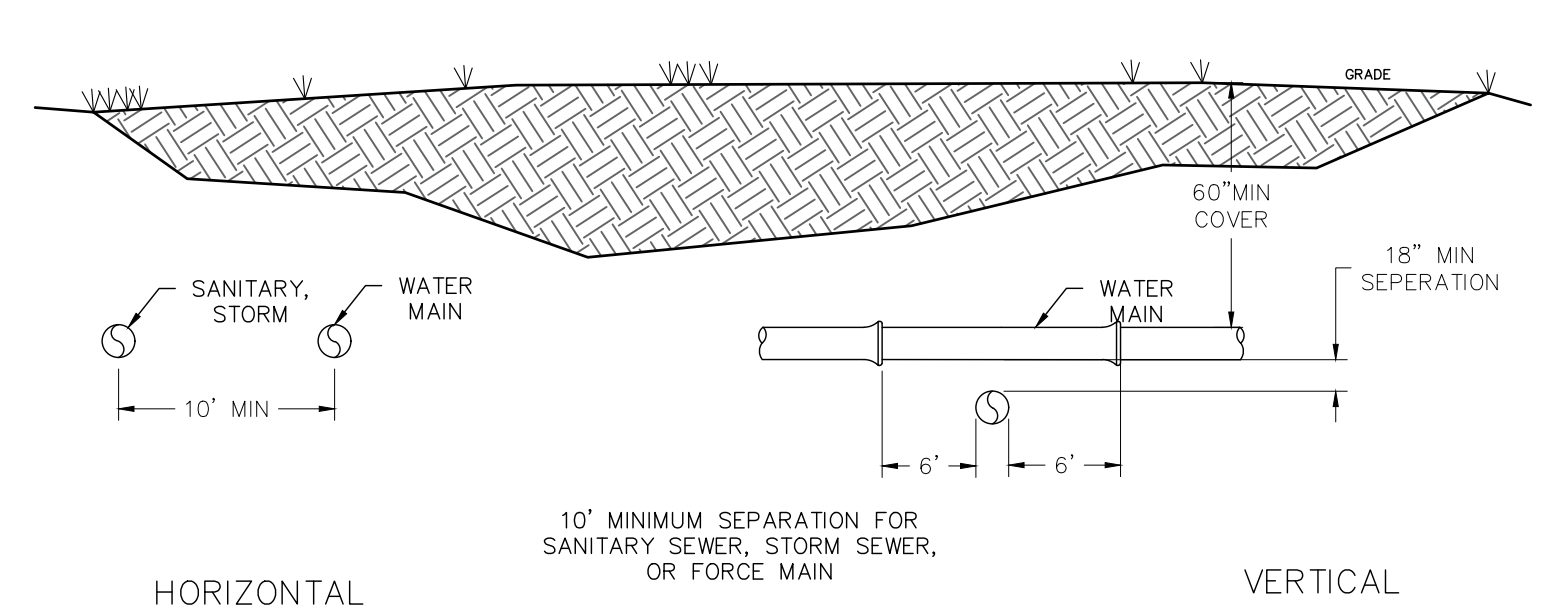

**NOTES**  
1. WATER MAINS SHALL BE SEPARATED FROM STORM SEWER, SANITARY SEWER, NON-POTABLE IRRIGATION MAINS, AND FORCE MAINS BY A MINIMUM CLEAR VERTICAL DISTANCE OF 18 INCHES MEASURED BETWEEN THE BOTTOM OF THE UPPER PIPE AND THE TOP OF THE LOWER PIPE. ALSO WATER MAINS MUST BE SEPARATED FROM STORM SEWER, SANITARY SEWERS, AND FORCE MAINS BY 10 FEET AND FROM IRRIGATION MAINS BY 5 FEET MEASURED HORIZONTALLY BETWEEN OUTSIDE OF PIPES.  
2. ALL CROSSINGS WITH VERTICAL CLEARANCE LESS THAN 18 INCHES SHALL BE MADE USING THICKNESS CLASS 200 AWMA C-900 DR14, PVC (CLASS 165 AWMA C-905, DR 25, PVC FOR PIPES GREATER THAN 12" DIAMETER) OR DUCTILE IRON, PRESSURE CLASS 250 PIPE FOR A HORIZONTAL DISTANCE OF 10 FEET ON EACH SIDE OF THE CROSSING. WATER MAIN CONCRETE ENCASEMENT SHALL ONLY BE MADE AFTER WRITTEN APPROVAL OF THE WATER DIRECTOR OR HIS/HER DESIGNEE. (SEPARATION REQUIREMENTS ALSO APPLY TO WATER AND SEWER LATERALS).  
3. 18 INCHES CLEAR DISTANCE SHALL NOT BE REDUCED IN CASES WHERE WATER CROSSES UNDER SEWER LINE.  
4. WATER MAINS, SANITARY SEWERS, STORM SEWER, AND NON-POTABLE IRRIGATION MAINS SHALL BE IN SEPARATE TRENCHES.

**3** PIPE SEPERATION DETAIL  
**501** NOT TO SCALE

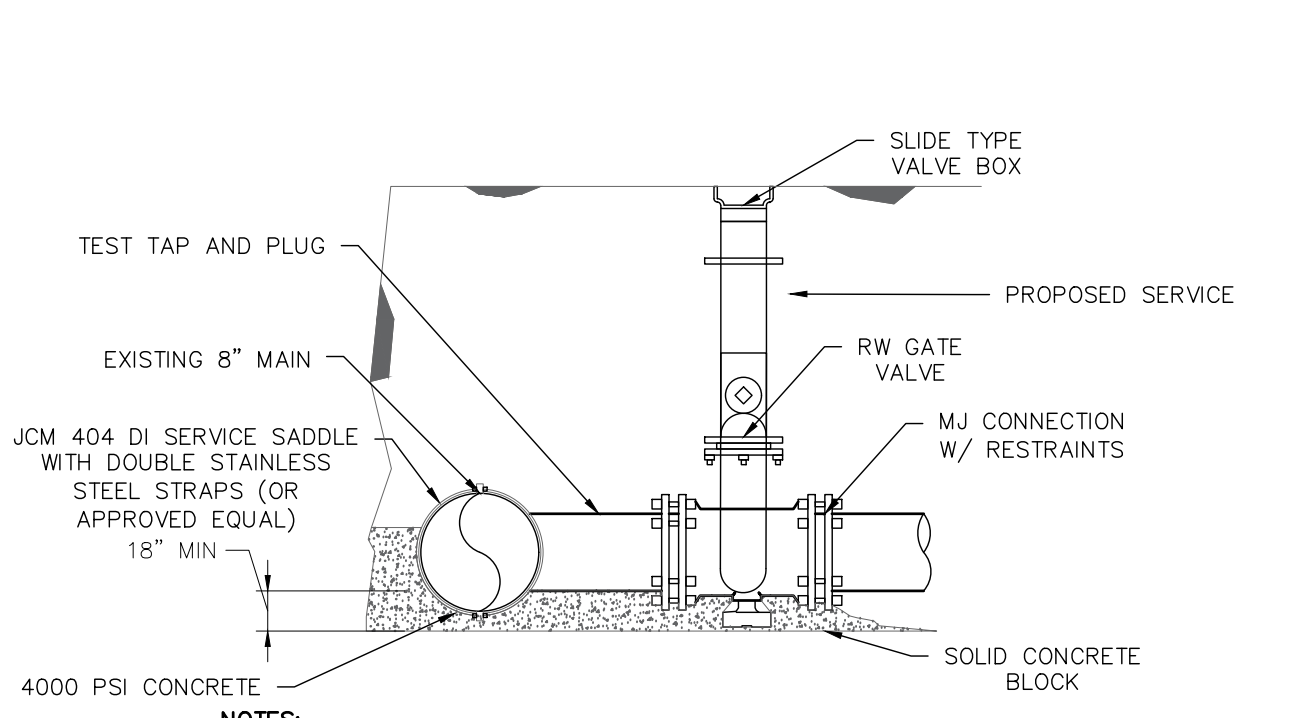

**NOTES**  
1. TEMPORARILY SUPPORT TAPPING SADDLE AND VALVE AND APPLY STANDARD HYDROSTATIC TEST.  
2. IF NO LEAKS, POUR INDICATED PERMANENT CONCRETE BLOCK AND SUPPORT PAD.  
3. MAKE TAP, LINE EXTENSION AND BACKFILL.  
4. COVER UP GLANDS AND BOLTS WITH HEAVY POLYETHYLENE SHEETING TO KEEP CONCRETE FROM BONDING. TYPICAL WHENEVER BOLTS OR GLANDS MAY BE "WRAPPED-UP" IN CONCRETE.  
5. COAT TAPPING SLEEVE AND BOLTS WITH AN APPROVED BITUMASTIC COATING BEFORE POURING CONCRETE. TYPICAL FOR ALL STEEL INCLUDING, RODS, COUPLINGS, STRAPS, AND OTHER BURIED STEEL.

**4** TAPPING SLEEVE AND VALVE DETAIL  
**501** NOT TO SCALE

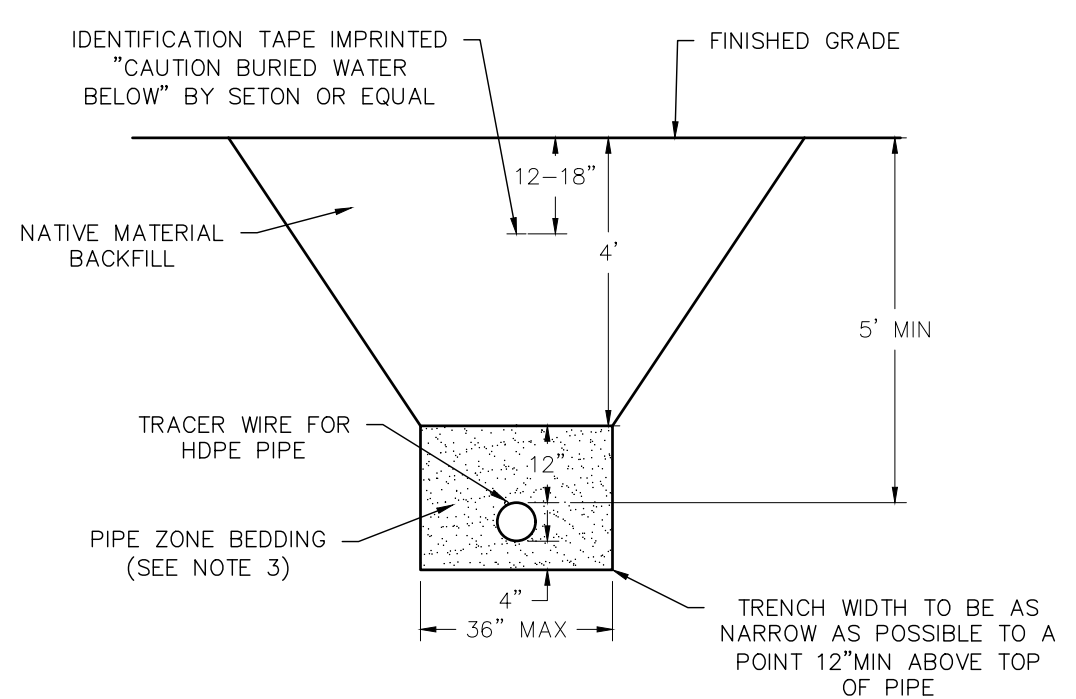

**NOTES**  
1. WATER SERVICE LATERAL SHALL BE INSTALLED IN ACCORDANCE WITH APPLICABLE MUNICIPAL SPECIFICATIONS.  
2. INDIVIDUAL SIZE SHALL BE DETERMINED BASED ON REQUIRED FLOW TO STRUCTURE.  
3. SAND SHALL BE FROM AN APPROVED SOURCE COMPACTED IN 6" LIFTS TO MINIMUM 12" ABOVE TOP OF PIPE.

**5** WATER SERVICE DETAIL  
**501** NOT TO SCALE

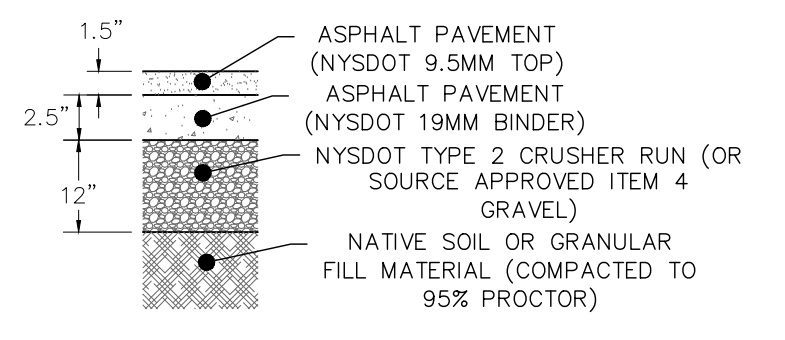

**NOTES**  
1. ITEM 4 GRAVEL MAY BE USED IN-LEU OF TYPE 2 CRUSHER RUN ONLY A.O.B.E.  
2. ALL IMPORTED MATERIAL SHALL BE COMPACTED TO 95% PROCTOR.

**6** ASPHALT PAVEMENT DETAIL  
**501** NOT TO SCALE

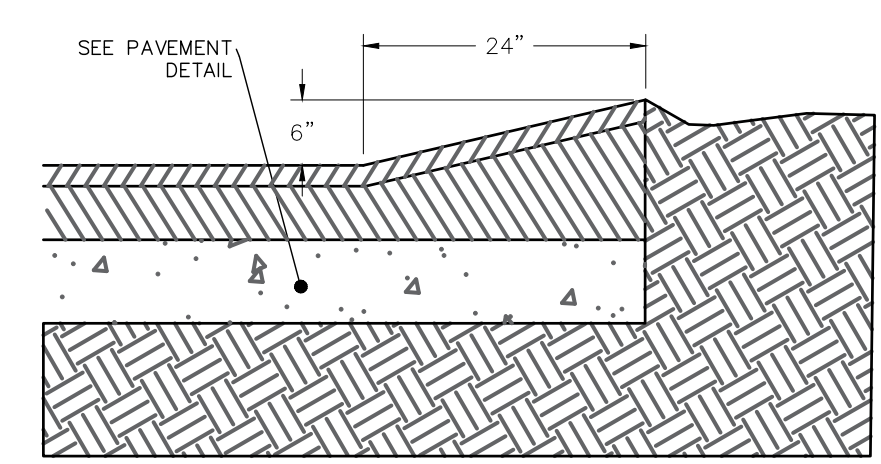

**7** ASPHALT WING WEDGE DETAIL  
**501** NOT TO SCALE

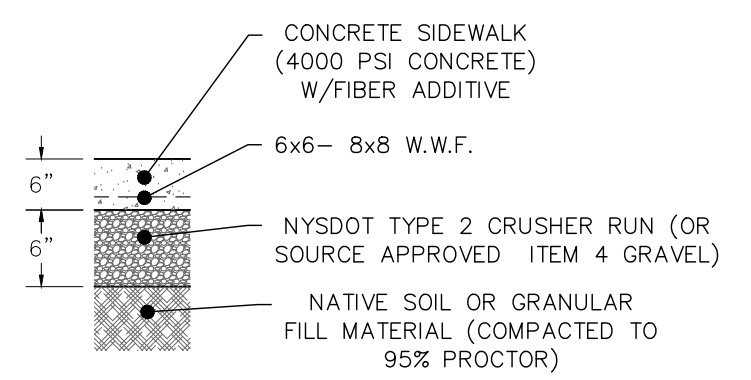

**NOTES**  
1. 5' TYPICAL WIDTH  
2. BROOM FINISH  
3. PROVIDE A TOOLED JOINT EVERY 5'  
4. SAWCUT CONTROL JOINTS EVERY 20'

**8** CONCRETE DETAIL  
**501** NOT TO SCALE

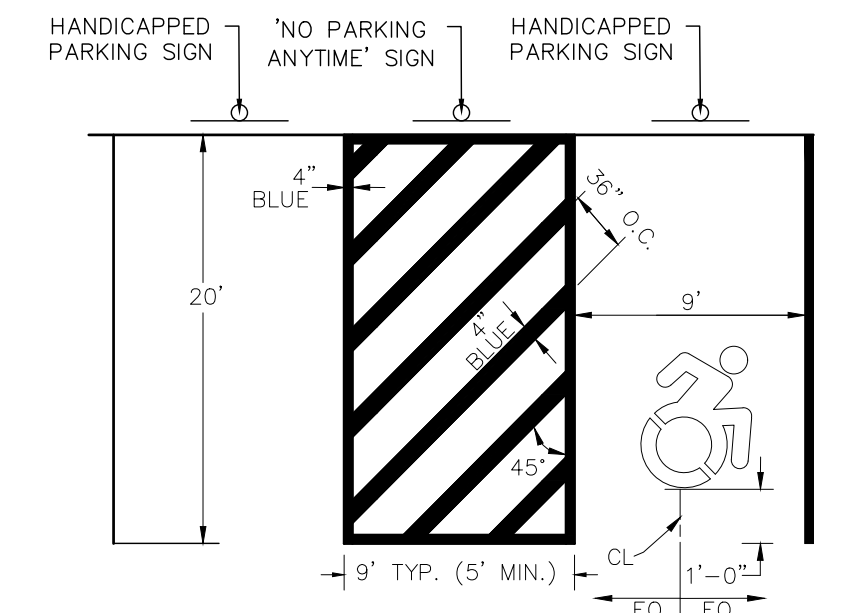

**NOTES**  
1. ALL DIMENSIONS SHALL BE IN ACCORDANCE WITH ADA STANDARDS AND CURRENT ZONING AND SITE REGULATIONS.  
2. PAINTED HANDICAP SYMBOL TO BE IN ACCORDANCE WITH ADA STANDARDS.  
3. SLOPE OF PAVEMENT SURFACE IN HANDICAP PARKING SHALL NOT EXCEED 2% IN ANY DIRECTION.  
4. SEE PLAN FOR ACTUAL LOCATION OF SIGNAGE.

**9** TYPICAL HANDICAPPED SPACE DETAIL  
**501** NOT TO SCALE

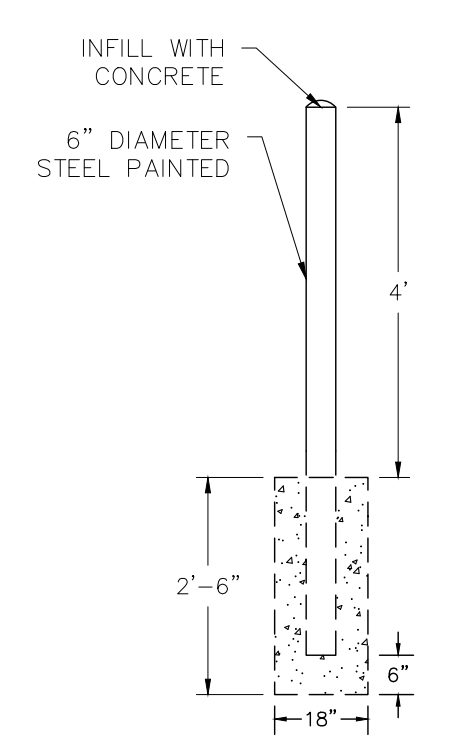

**NOTES**  
1. BOLLARDS SHALL BE PAINTED FOR HIGH VISIBILITY, AND FOR PREVENTION OF RUST.

**10** BOLLARD DETAIL  
**501** NOT TO SCALE

MUTCD	R7-8	R7-1	R7-8P	R1-1
SIZE	18"x9"	24"x30"	18"x9"	30"x30"
HT.	7'	7'	7'	7'

**NOTES**  
1. ALL SIGNS SHALL BE INSTALLED USING A TYPE "A" SIGN POST.  
2. ALL SIGNS SHALL CONFORM TO THE FHWA MUTCD STANDARDS AND THE NYS SUPPLEMENT H.C. SIGN POST SHALL BE SET IN BOLLARD PRIOR TO FILLING WITH CONCRETE.

**11** SIGN TABLE  
**501** NOT TO SCALE

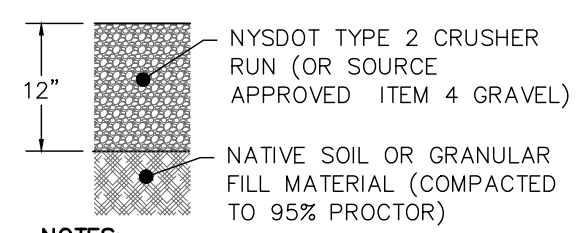

**NOTES**  
1. ITEM 4 GRAVEL MAY BE USED IN-LEU OF TYPE 2 CRUSHER RUN ONLY A.O.B.E.  
2. ALL IMPORTED MATERIAL SHALL BE COMPACTED TO 95% PROCTOR.

**12** GRAVEL AREA DETAIL  
**501**

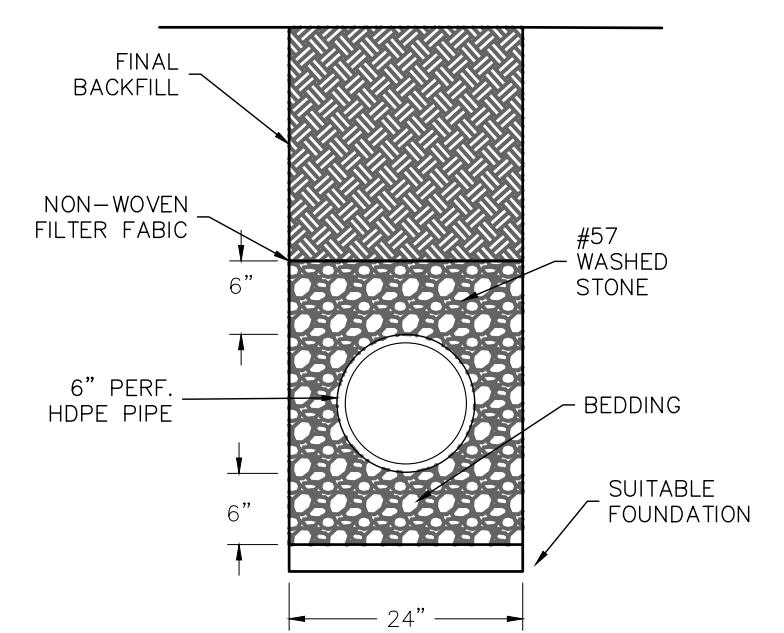

**13** UNDERDRAIN DETAIL  
**501** NOT TO SCALE

Date	Revision Description
11/3/21	MISC. REVISIONS

PRIOR TO ANY EARTH DISTURBANCE THE CONTRACTOR SHALL CALL IN A TICKET TO DIG SAFE NY AND OBTAIN A CLEAR TO DIG

IT IS A VIOLATION OF SECTION 7209 OF THE NYS EDUCATION LAW FOR ANY PERSON TO ALTER ANY ITEM ON THIS PLAN IN ANY WAY UNLESS HE/SHE IS ACTING UNDER THE DIRECT SUPERVISION OF A PROFESSIONAL ENGINEER.

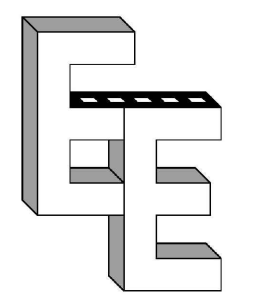

EMPIRE ENGINEERING, PLLC  
1900 DUANESBURG ROAD  
DUANESBURG, NY 12056  
PH: (518) 858-4117  
EMAIL: CLONGO@EMPIREENG.NET

PROJECT  
DAIM LOGISTICS, INC.  
128 PARK DRIVE  
GLEN PARK  
FULTONVILLE, NY 12072

Title	
SITE & UTILITY DETAILS	
Date	Sheet
10/21/2021	C501
Scale	Sheet 3 of 5
AS SHOWN	

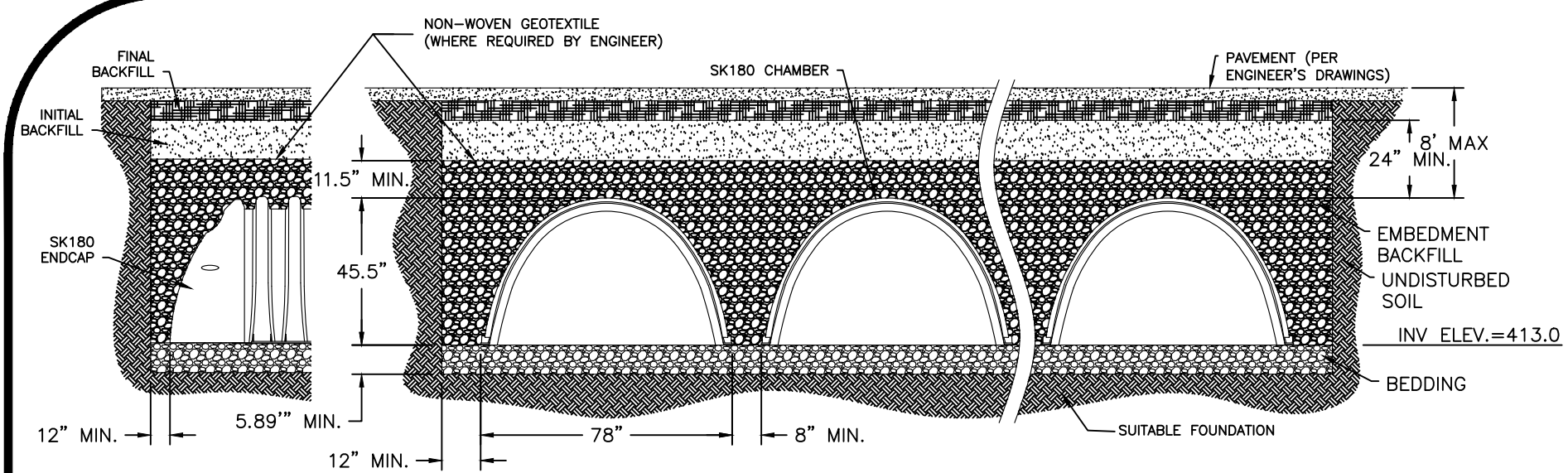

1  
502 TYPICAL STORM CHAMBER CROSS SECTION DETAIL  
SK180 CHAMBER BY LANE ENTERPRISES OR APPROVED EQUAL

STORM CHAMBER ELEVATION TABLE:	
1-YR:	414.06
10-YR:	414.79
100-YR:	416.91

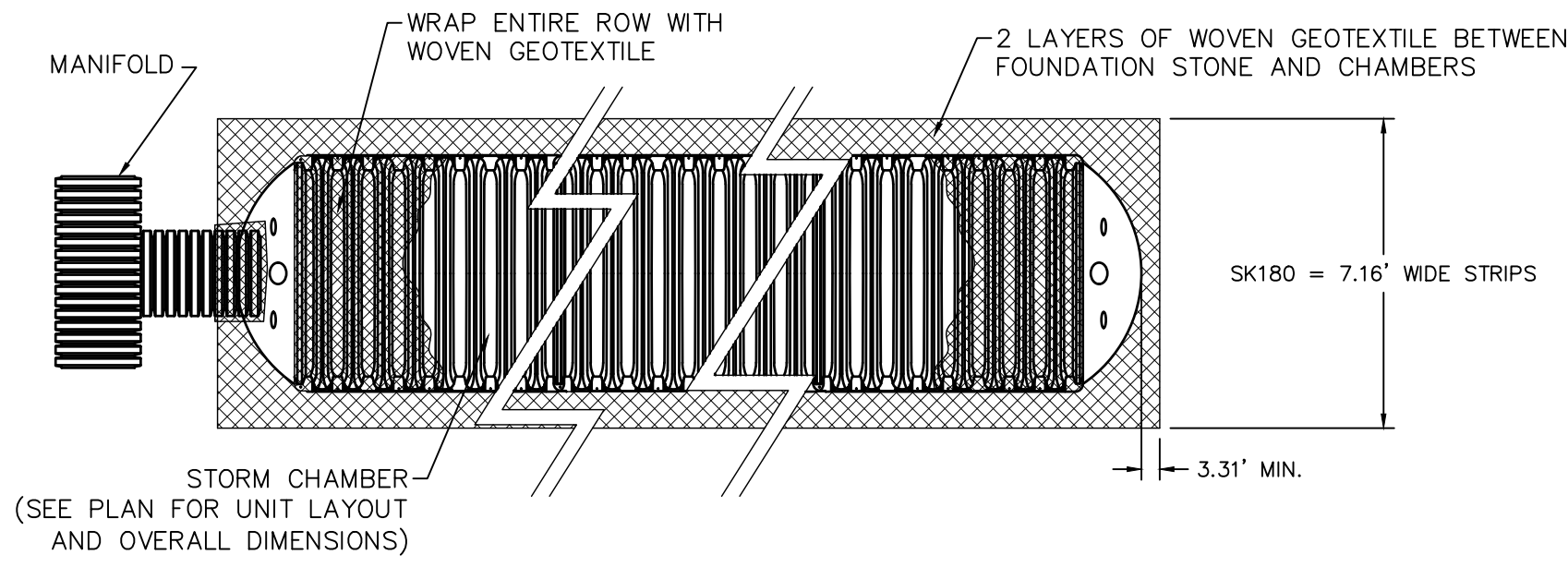

2  
502 STORM CHAMBER PLAN VIEW  
NOT TO SCALE

- NOTES:**
- CHAMBER SYSTEMS SHALL BE INSTALLED IN ACCORDANCE WITH THE MANUFACTURER'S LATEST INSTALLATION GUIDELINES.
  - FOUNDATION: TRENCH BOTTOMS WITH UNSTABLE OR UNYIELDING MATERIAL SHALL BE EXCAVATED TO A DEPTH DIRECTED BY THE ENGINEER AND REPLACED WITH SUITABLE MATERIAL. FOR UNSTABLE MATERIALS, GEOTEXTILE MAY BE USED TO STABILIZE THE TRENCH BOTTOM, IF DIRECTED BY THE ENGINEER. THE DESIGN ENGINEER IS RESPONSIBLE FOR VERIFYING FOUNDATION SUITABILITY.
  - GEOTEXTILE: A 6oz NON-WOVEN GEOTEXTILE FILTER FABRIC (AASHTO M288 CLASS 2) SHOULD BE USED TO PREVENT NATIVE SOIL FROM MIGRATING INTO THE INITIAL BACKFILL MATERIAL.
  - BEDDING: SUITABLE MATERIAL SHALL BE A 3/4 - 2 INCH, CLEAN, CRUSHED ANGULAR STONE, OR AASHTO M43 SIZES (3, 357, 4, 467, 5, 56, 57) WITH CLEAN, CRUSHED, ANGULAR STONE ADDED TO THE GRADATION, e.g., CLEAN, CRUSHED, ANGULAR #3 (AASHTO M43) STONE. MINIMUM BEDDING THICKNESS SHALL BE 9 INCHES. COMPACTION SHOULD BE DONE IN LIFTS OF NO MORE THAN 9 INCHES TO A DENSITY OF 95% STANDARD PROCTOR DENSITY.
  - EMBEDMENT BACKFILL: SUITABLE MATERIAL SHALL BE A 3/4 - 2 INCH, CLEAN, CRUSHED ANGULAR STONE, OR AASHTO M43 SIZES (3, 357, 4, 467, 5, 56, 57) WITH CLEAN, CRUSHED, ANGULAR STONE ADDED TO THE GRADATION, e.g., CLEAN, CRUSHED, ANGULAR #3 (AASHTO M43) STONE. MINIMUM BEDDING THICKNESS SHALL BE 9 INCHES. EMBEDMENT BACKFILL SHALL EXTEND FROM TOP OF BEDDING TO NOT LESS THAN 11 1/2 INCHES ABOVE THE TOP OF THE CHAMBER. NO COMPACTION IS REQUIRED BUT AN EFFORT SHOULD BE MADE TO HAND KNIFE STONE INTO ALL CORRUGATIONS.
  - INITIAL BACKFILL: SUITABLE MATERIAL SHALL BE A GRANULAR, WELL GRADED SOIL WITH LESS THAN 35% FINES OR AASHTO M43 SIZES (3, 357, 4, 467, 5, 56, 57, 6, 67, 68, 7, 78, 8, 89, 9, 10) WITH CLEAN, CRUSHED, ANGULAR STONE ADDED TO THE GRADATION. INITIAL BACKFILL SHALL EXTEND FROM TOP OF EMBEDMENT BACKFILL TO NOT LESS THAN 24 INCHES ABOVE THE TOP OF THE CHAMBER. COMPACTION SHOULD BE BROUGHT TO A MINIMUM OF 95% STANDARD PROCTOR DENSITY.
  - FINAL BACKFILL: SUITABLE MATERIALS SHALL BE ANY SOIL DIRECTED BY THE ENGINEER. FINAL BACKFILL SHALL EXTEND FROM TOP OF INITIAL BACKFILL TO NO MORE THAN 8 FEET ABOVE THE TOP OF THE CHAMBER. COMPACTION LEVELS SHOULD FOLLOW ENGINEERS RECOMMENDATIONS.
  - MINIMUM COVER: FOR UP TO H-25 TRAFFIC APPLICATIONS A MINIMUM COVER OF 24 INCHES IS REQUIRED, MEASURED FROM THE TOP OF THE CHAMBER TO THE BOTTOM OF THE FLEXIBLE PAVEMENT. ADDITIONAL COVER MAY BE REQUIRED FOR CONSTRUCTION LOADS OR WHERE RUTTING MAY TAKE PLACE.
  - MAXIMUM COVER: A COVER HEIGHT OF OVER 8 FEET IS NOT RECOMMENDED. COVER HEIGHT IS MEASURED FROM THE TOP OF THE CHAMBER TO THE TOP OF THE PAVEMENT.

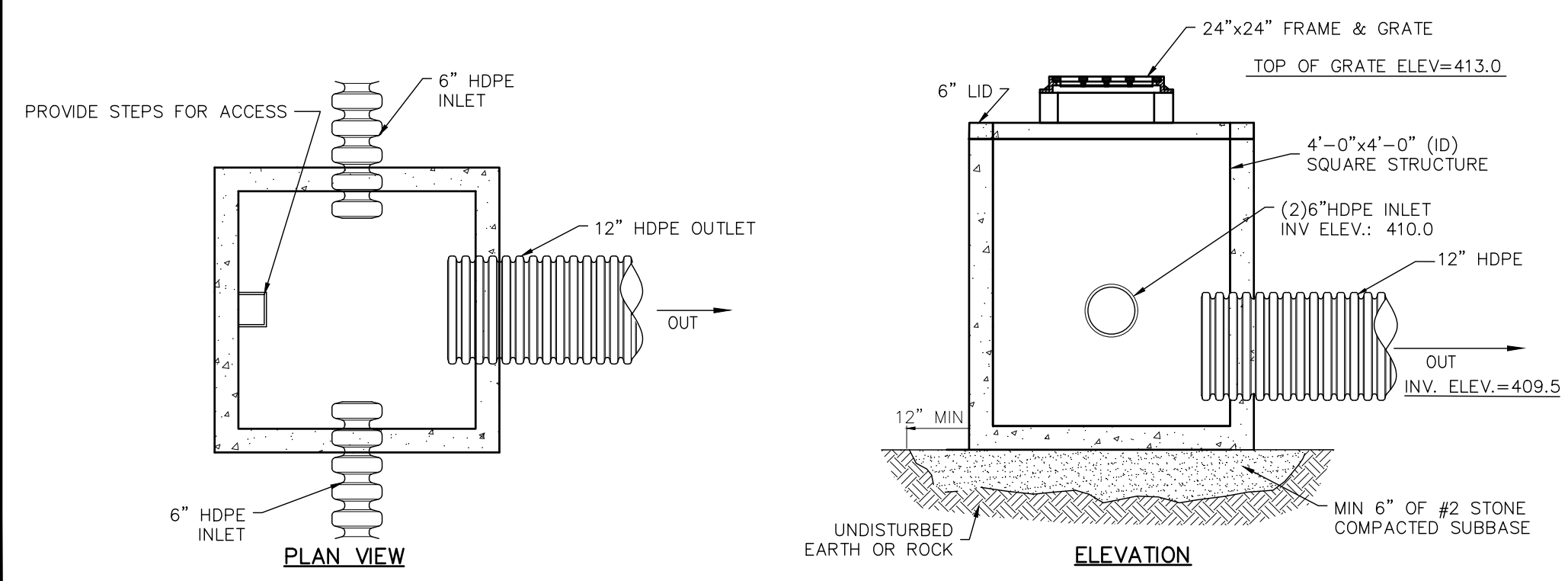

8  
502 STORMWATER OUTLET CONTROL STRUCTURE (OCS1)

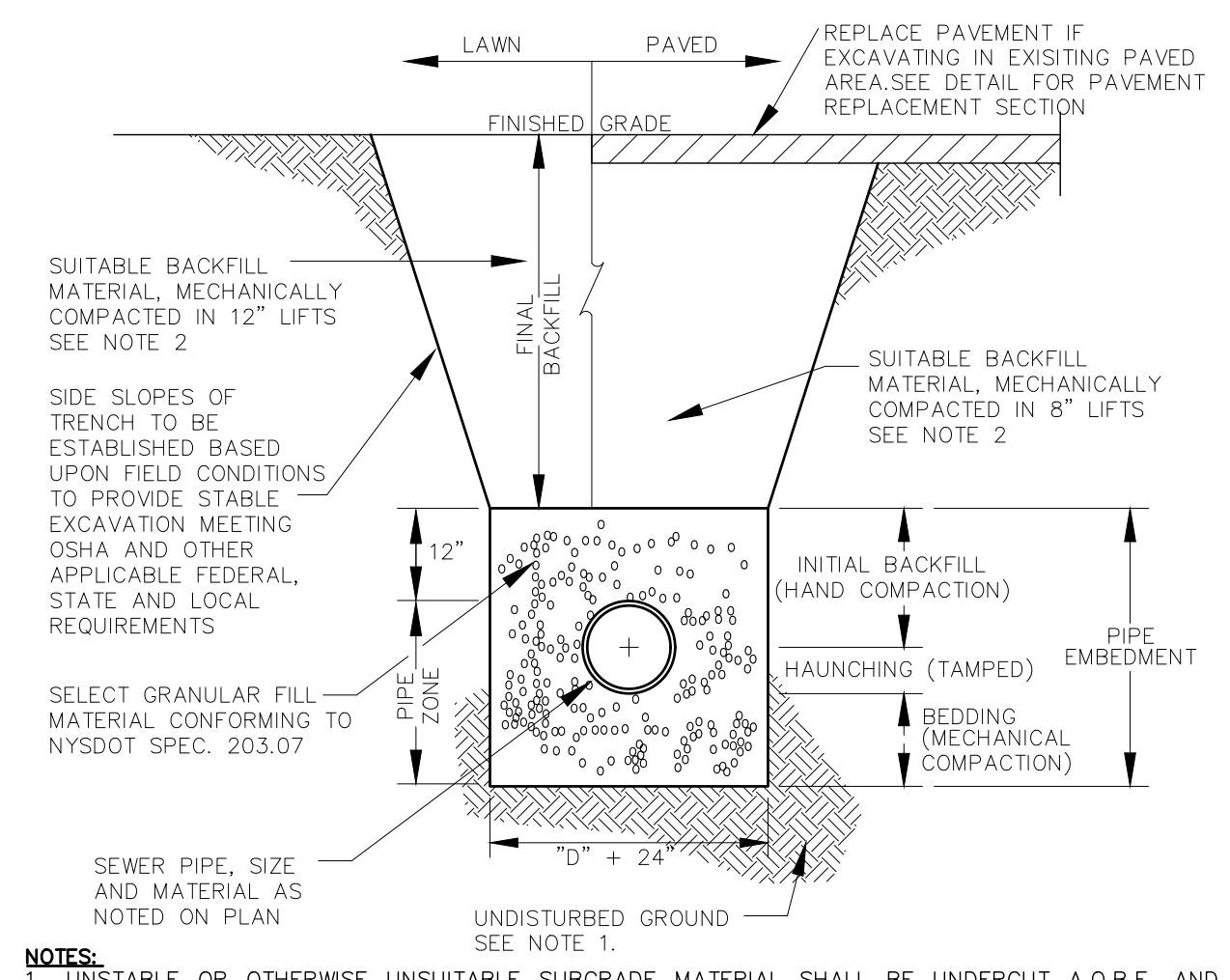

3  
502 TYPICAL TRENCH DETAIL  
NOT TO SCALE

- NOTES:**
- UNSTABLE OR OTHERWISE UNSUITABLE SUBGRADE MATERIAL SHALL BE UNDERCUT A.O.B.E. AND REPLACED WITH SELECT FILL MATERIAL.
  - ALL BACKFILL MATERIAL SHALL CONFORM TO NYS DOT ITEM 203.06 COMPACTED TO 90% STD. PROCTOR MAX. DENSITY.

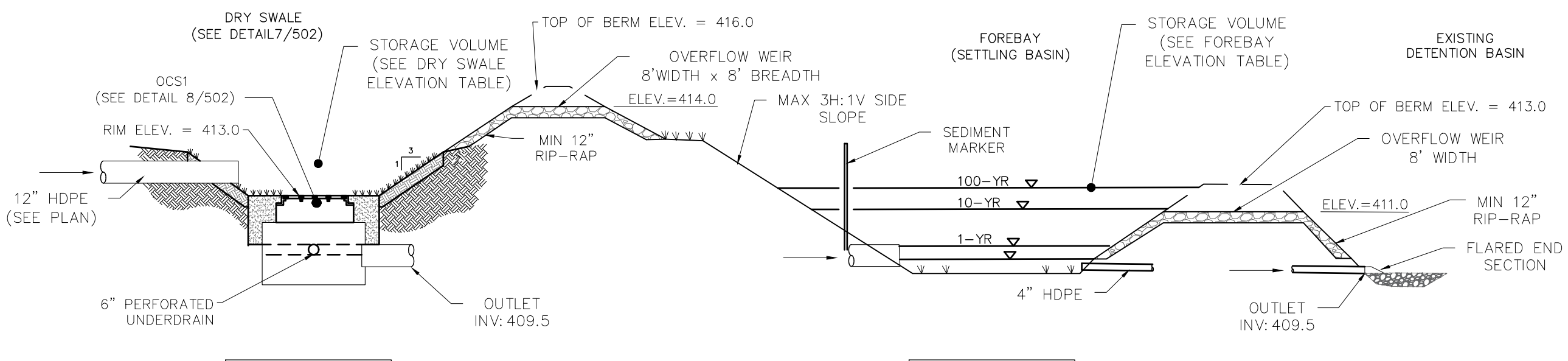

DRY SWALE ELEVATION TABLE:	
1-YR:	413.27
10-YR:	413.57
100-YR:	414.99

FOREBAY ELEVATION TABLE:	
1-YR:	410.21
10-YR:	411.14
100-YR:	411.76

- NOTES:**
- A MINIMUM 6" THICK CLAY LINER SHALL BE INSTALLED WITHIN THE MICROPOL AND FOREBAY. MATERIAL SHALL BE FROM A SOURCE APPROVED BY THE ENGINEER AND BE GREATER THAN 50% PASSING THE #200 SIEVE.
  - OVERFLOW WEIR SHALL BE CONSTRUCTED WITH A MIN OF 12" D50=6" RIP RAP LAID OVER GEOTEXTILE FABRIC.
  - SEDIMENT MARKER SHALL BE A MINIMUM 2" SCHEDULE 40 PVC PIPE BURIED A MIN 4 FT AND 2 FT ABOVE PERMANENT POOL ELEVATION. A SOLID MARK SHALL BE PLACED AT A POINT 2FT ABOVE THE FOREBAY BOTTOM.
  - SIDE SLOPES SHALL BE 4H:1V FOR FOREBAY, 3H:1V ABOVE THE AQUATIC BENCH AND 2H:1V BELOW THE AQUATIC BENCH.
  - EMERGENT PLANTINGS WITHIN THE AQUATIC BENCH SHALL BE HYDROLOGIC ZONE 2, CAPABLE OF WITHSTANDING CONSTANT INUNDATION. PLANTINGS SHALL BE RANDOMLY SPACED 5-10' O.C. AND SHALL BE SELECTED FROM THE LIST ON TABLE H.5 OF THE NYSDEC STORMWATER DESIGN MANUAL. A LARGE DEEP HOLE SHOULD BE DUG AROUND EACH PLANTING SITE AND NATIVE SOIL REPLACED WITH UNCOMPACTED TOPSOIL.

6  
502 DRY SWALE / FOREBAY PROFILE  
NOT TO SCALE

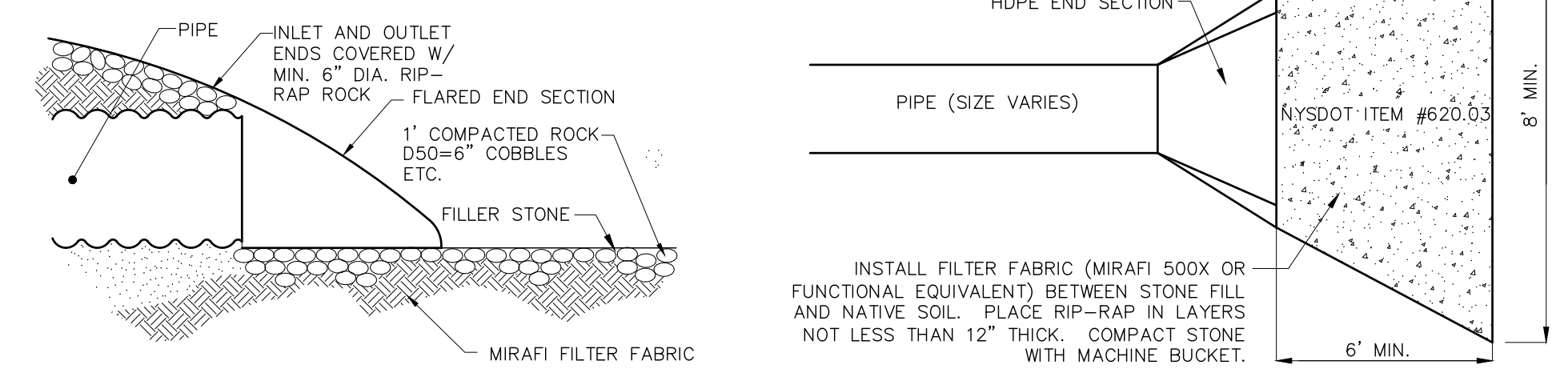

- NOTES:**
- REFERENCE PAGE 3.39 OF NYS STANDARDS & SPECIFICATIONS FOR EROSION & SEDIMENT CONTROL 'BLUE BOOK'.
  - DISCHARGE FLOW IS MINIMUM TAILWATER CONDITION FOR ALL PIPING EXCEPT AS NOTED BELOW, MAXIMUM Q = 3 CFS
  - ALL END SECTIONS: LENGTH OF APRON (L<sub>a</sub>) = 6 FT  
WIDTH OF APRON = 8 FT
  - D<sub>50</sub> = 6" RIP-RAP. SIZE EQUIVALENT TO NYS DOT LIGHT STONE FILL

9  
502 PIPE FLARED END SECTION DETAIL

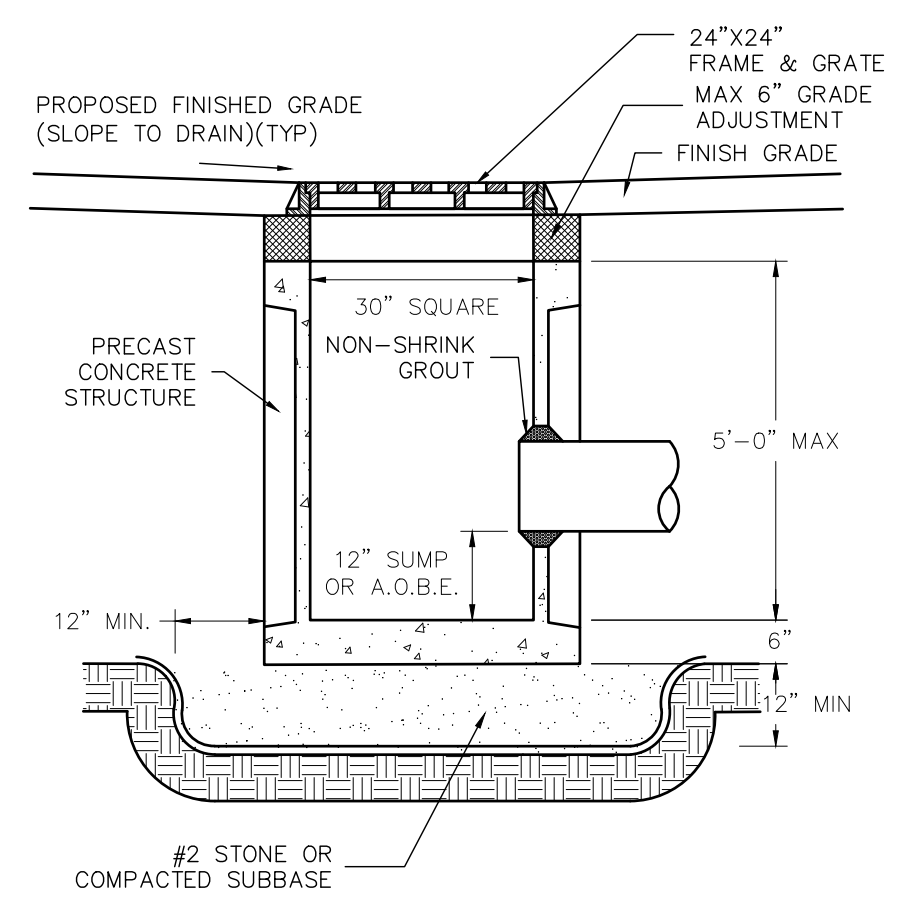

4  
502 PRECAST CONCRETE STORM CATCH BASIN

- NOTES:**
- FRAME AND GRATE/COVER FOR EACH STORM STRUCTURE SHALL BE SET IN MORTAR BED.
  - FRAME AND GRATE SHALL BE MANUFACTURED BY EJ PRESCOTT OR APPROVED EQUAL.
  - STRUCTURE TO BE RATED FOR H20 LOADING.

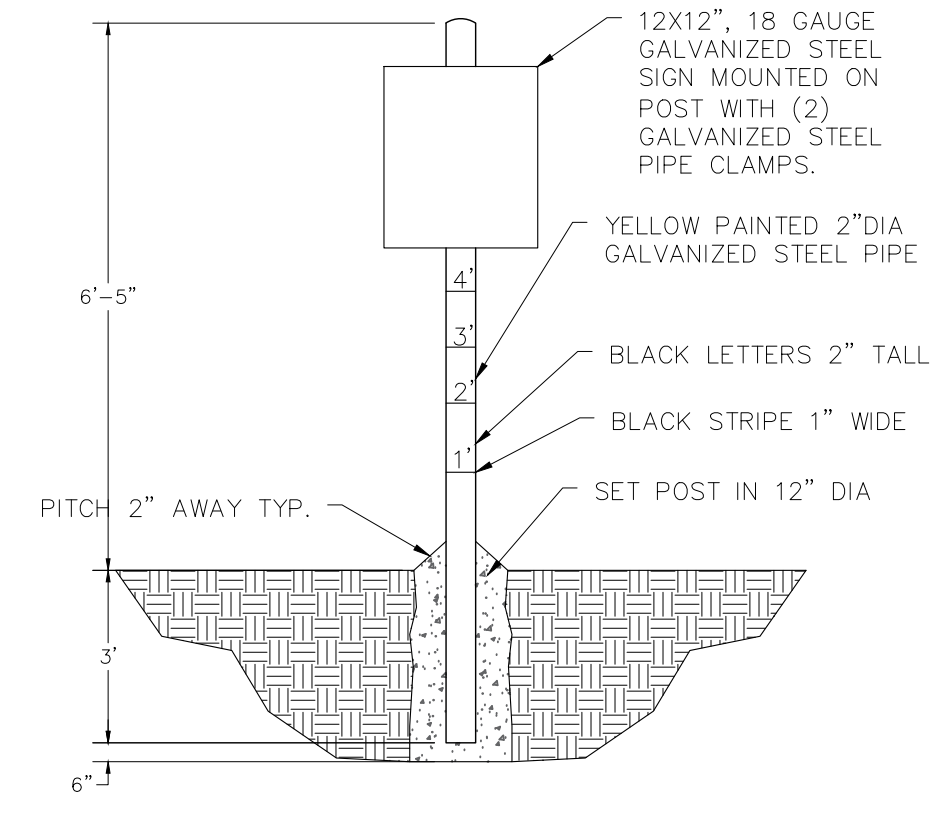

5  
502 SEDIMENT MARKER DETAIL  
NOT TO SCALE

- NOTES:**
- SIGN SHALL READ "THIS MARKER IS PART OF AN ON-SITE STORM WATER MANAGEMENT FACILITY".
  - SEDIMENT SHALL BE REMOVED FROM THE SEDIMENTATION BASIN WHEN IT IS 50% FULL (AT THE 2-FOOT MARK)
  - SIGN SHALL HAVE WHITE BACKGROUND, WITH 1" TALL BLACK LETTERS.

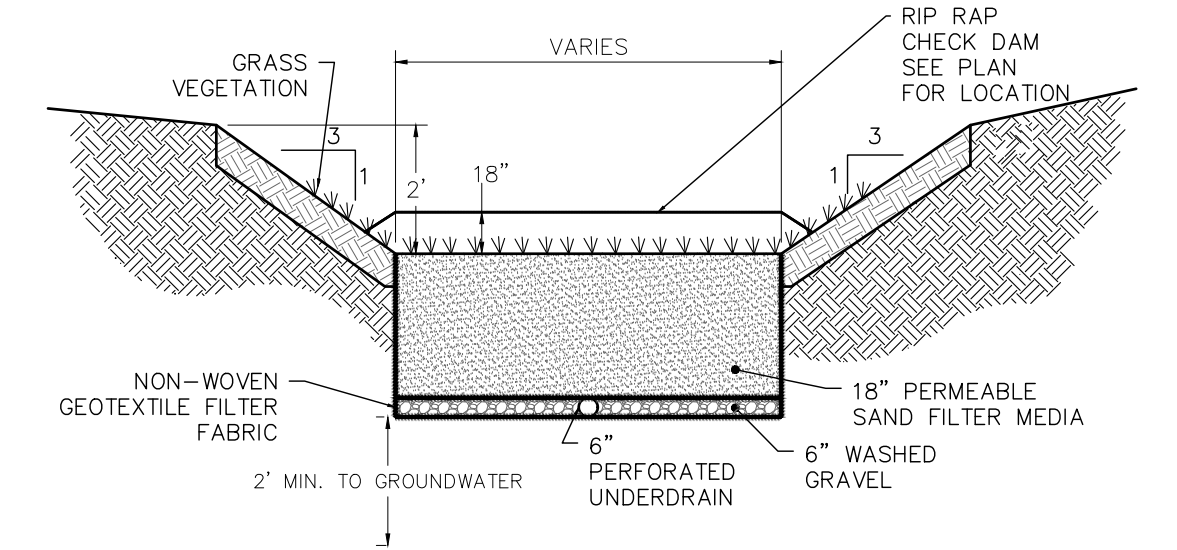

7  
502 DRY SWALE DETAIL

- NOTES:**
- DISTURBED AREAS SHALL BE PLANTED WITH ENVIRONMENTAL SEED MIX.
  - VEGETATION SHALL BE MAINTAINED AT 6" HEIGHT.
  - ALL TREES, BRUSH, STUMPS AND OTHER OBSTRUCTIONS SHALL BE REMOVED AND DISPOSED OF SO AS NOT TO INTERFERE WITH THE PROPER FUNCTION OF THE SWALE.
  - THE SWALE SHALL BE EXCAVATED OR SHAPED TO MEET THE CROSS SECTION SHOWN ABOVE AND SHALL BE FREE OF BANK PROJECTIONS OR OTHER IRREGULARITIES THAT MAY IMPEDE FLOW.
  - NON-WOVEN GEOTEXTILE FABRIC SHALL BE INSTALLED ON THE BOTTOM AND SIDES OF THE TRENCH AS WELL AS BETWEEN THE STONE AND SAND LAYERS.

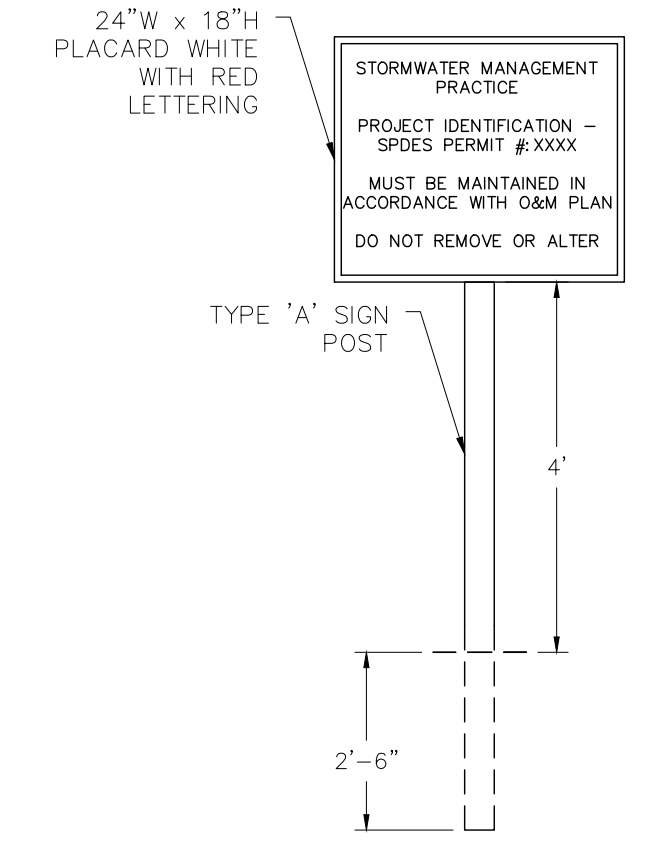

- NOTES:**
- ALL SIGNS SHALL BE INSTALLED USING A TYPE 'A' SIGN POST.

10  
502 STORMWATER AREA SIGN  
NOT TO SCALE

Date	11/3/21
Revision Description	MISC. REVISIONS
No.	1

PRIOR TO ANY EARTH DISTURBANCE THE CONTRACTOR SHALL CALL IN A TICKET TO DIG SAFE NY AND OBTAIN A CLEAR TO DIG

IT IS A VIOLATION OF SECTION 7209 OF THE NYS EDUCATION LAW FOR ANY PERSON TO ALTER ANY ITEM ON THIS PLAN IN ANY WAY UNLESS HE/SHE IS ACTING UNDER THE DIRECT SUPERVISION OF A PROFESSIONAL ENGINEER.

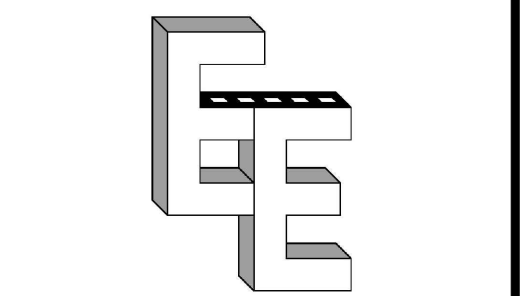

EMPIRE ENGINEERING, PLLC  
1900 DUANESBURG ROAD  
DUANESBURG, NY 12056  
PH: (518) 858-4117  
EMAIL: CLONGO@EMPIREENG.NET

PROJECT  
DAIM LOGISTICS, INC.  
128 PARK DRIVE  
GLEN PARK  
FULTONVILLE, NY 12072

Title  
STORM DETAILS

Date	10/21/2021	Sheet	C502
Scale	AS SHOWN	Sheet 4 of 5	

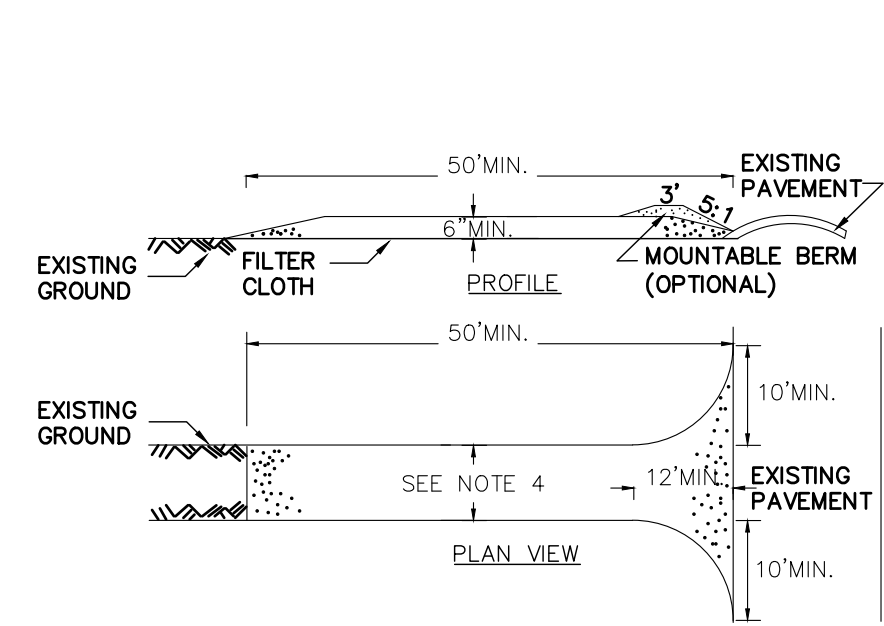

- NOTES:**
- STONE SIZE - USE 1-4 INCH STONE, OR RECLAIMED OR RECYCLED CONCRETE EQUIVALENT.
  - LENGTH - NOT LESS THAN 50 FEET (EXCEPT ON A SINGLE RESIDENCE LOT WHERE A 30 FOOT MINIMUM LENGTH WOULD APPLY).
  - THICKNESS - NOT LESS THAN SIX (6) INCHES.
  - WIDTH - TWELVE (12) FOOT MINIMUM, BUT NOT LESS THAN THE FULL WIDTH AT POINTS WHERE INGRESS OR EGRESS OCCURS. TWENTY-FOUR (24) FOOT IF SINGLE ENTRANCE TO SITE.
  - GEOTEXTILE - WILL BE PLACED OVER THE ENTIRE AREA PRIOR TO PLACING OF STONE.
  - SURFACE WATER - ALL SURFACE WATER FLOWING OR DIVERTED TOWARD CONSTRUCTION ACCESS SHALL BE PIPED BENEATH THE ENTRANCE. IF PIPING IS IMPRACTICAL, A MOUNTABLE BERM WITH 5:1 SLOPES WILL BE PERMITTED.
  - MAINTENANCE - THE ENTRANCE SHALL BE MAINTAINED IN A CONDITION WHICH WILL PREVENT TRACKING OR FLOWING OF SEDIMENT ONTO PUBLIC RIGHTS-OF-WAY. ALL SEDIMENT SPILLED, DROPPED, WASHED OR TRACKED ONTO PUBLIC RIGHTS-OF-WAY MUST BE REMOVED IMMEDIATELY.
  - WHEN WASHING IS REQUIRED, IT SHALL BE DONE ON A AREA STABILIZED WITH STONE AND WHICH DRAINS INTO AN APPROVED SEDIMENT TRAPPING DEVICE.
  - PERIODIC INSPECTION AND NEEDED MAINTENANCE SHALL BE PROVIDED AFTER EACH RAIN.

1  
503 STABILIZED CONSTRUCTION ENTRANCE DETAIL  
NOT TO SCALE

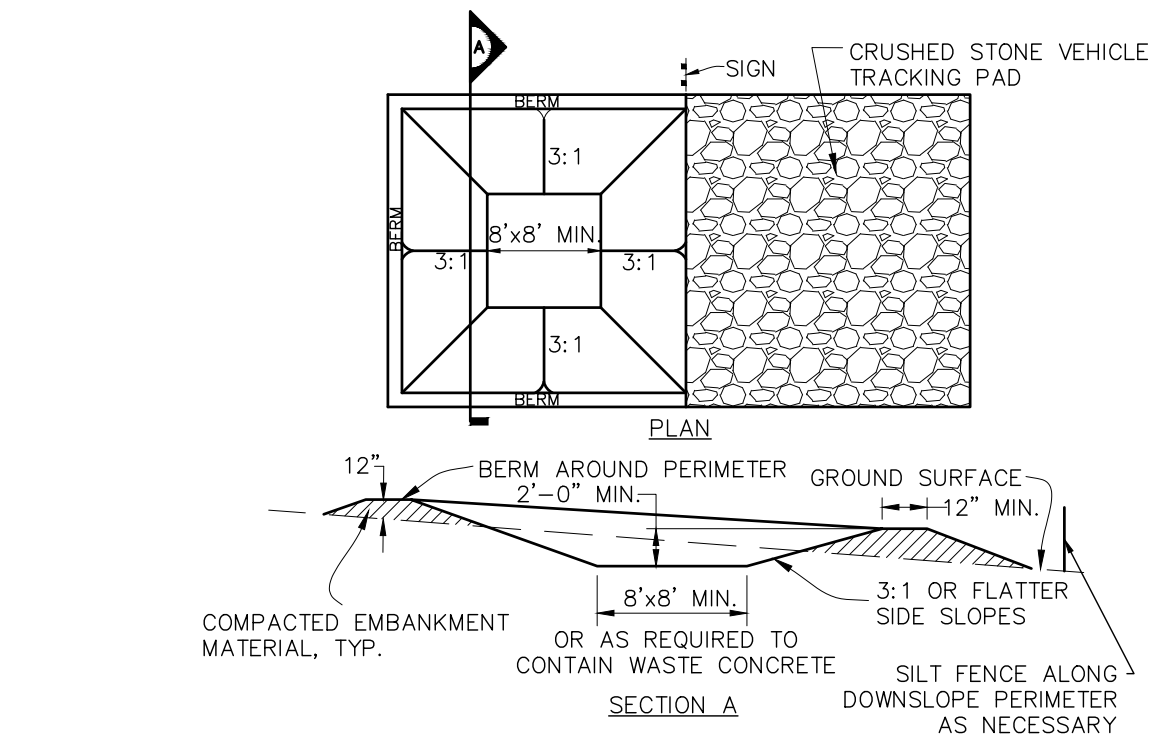

- CONCRETE WASHOUT AREA INSTALLATION NOTES:**
- SEE PLAN VIEW FOR LOCATIONS OF CONCRETE WASHOUT AREA
  - THE CONCRETE WASHOUT AREA SHALL BE INSTALLED PRIOR TO ANY CONCRETE PLACEMENT ON SITE.
  - VEHICLE TRACKING CONTROL IS REQUIRED AT THE ACCESS POINT.
  - SIGNS SHALL BE PLACED AT THE CONSTRUCTION ENTRANCE, AT THE WASHOUT AREA, AND ELSEWHERE AS NECESSARY TO CLEARLY INDICATE THE LOCATION OF CONCRETE WASHOUT AREA TO OPERATORS OF CONCRETE TRUCKS AND PUMP RIGS.
  - EXCAVATED MATERIAL SHALL BE UTILIZED IN PERIMETER BERM CONSTRUCTION.
- CONCRETE WASHOUT AREA MAINTENANCE NOTES:**
- THE CONCRETE WASHOUT AREA SHALL BE REPAIRED AND ENLARGED OR CLEANED UP AS NECESSARY TO MAINTAIN CAPACITY FOR WASTED CONCRETE.
  - AT THE END OF CONSTRUCTION, ALL CONCRETE SHALL BE REMOVED FROM THE SITE AND DISPOSED OF AT AN APPROVED WASTE SITE.
  - WHEN THE CONCRETE WASHOUT AREA IS REMOVED, COVER THE DISTURBED AREA WITH TOPSOIL, SEED AND MULCH OR OTHERWISE STABILIZE IN A MANNER APPROVED BY THE LOCAL JURISDICTION.
  - INSPECT WEEKLY, DURING AND AFTER ANY STORM EVENT.

2  
503 CONCRETE WASHOUT DETAIL  
NOT TO SCALE

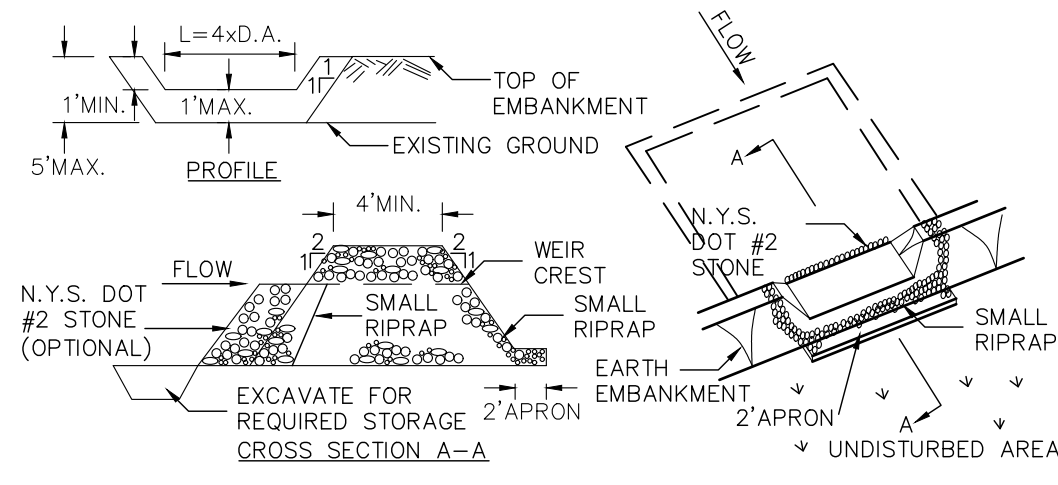

- NOTES:**
- AREA UNDER EMBANKMENT SHALL BE CLEARED, GRUBBED AND STRIPPED OF ANY VEGETATION AND ROOT MAT. THE POOL AREA SHALL BE CLEARED.
  - THE FILL MATERIAL FOR THE EMBANKMENT SHALL BE FREE OF ROOTS AND OTHER WOODY VEGETATION AS WELL AS OVER-SIZED STONES, ROCKS, ORGANIC MATERIAL OR OTHER OBJECTIONABLE MATERIAL. THE EMBANKMENT SHALL BE COMPACTED BY TRAVERSING WITH EQUIPMENT WHILE IT IS BEING CONSTRUCTED.
  - ALL CUT AND FILL SLOPES SHALL BE 2:1 OR FLATTER.
  - THE STONE USED IN THE OUTLET SHALL BE SMALL RIPRAP 4"-8" ALONG WITH A 1" THICKNESS OF 2" AGGREGATE PLACED ON THE UP-GRADE SIDE ON THE SMALL RIPRAP OR EMBEDDED FILTER CLOTH IN THE RIPRAP.
  - SEDIMENT SHALL BE REMOVED AND TRAP RESTORED TO ITS ORIGINAL DIMENSIONS WHEN THE SEDIMENT HAS ACCUMULATED TO 1/2 THE DESIGN DEPTH OF THE TRAP.
  - THE STRUCTURE SHALL BE INSPECTED AFTER EACH RAIN AND REPAIRS MADE AS NEEDED.
  - CONSTRUCTION OPERATIONS SHALL BE CARRIED OUT IN SUCH A MANNER THAT EROSION AND WATER POLLUTION IS MINIMIZED.
  - THE STRUCTURE SHALL BE REMOVED AND THE AREA STABILIZED WHEN THE DRAINAGE AREA HAS BEEN PROPERLY STABILIZED.
  - MAXIMUM DRAINAGE AREA 5 ACRES

3  
503 TEMPORARY SEDIMENT TRAP DETAIL  
NOT TO SCALE

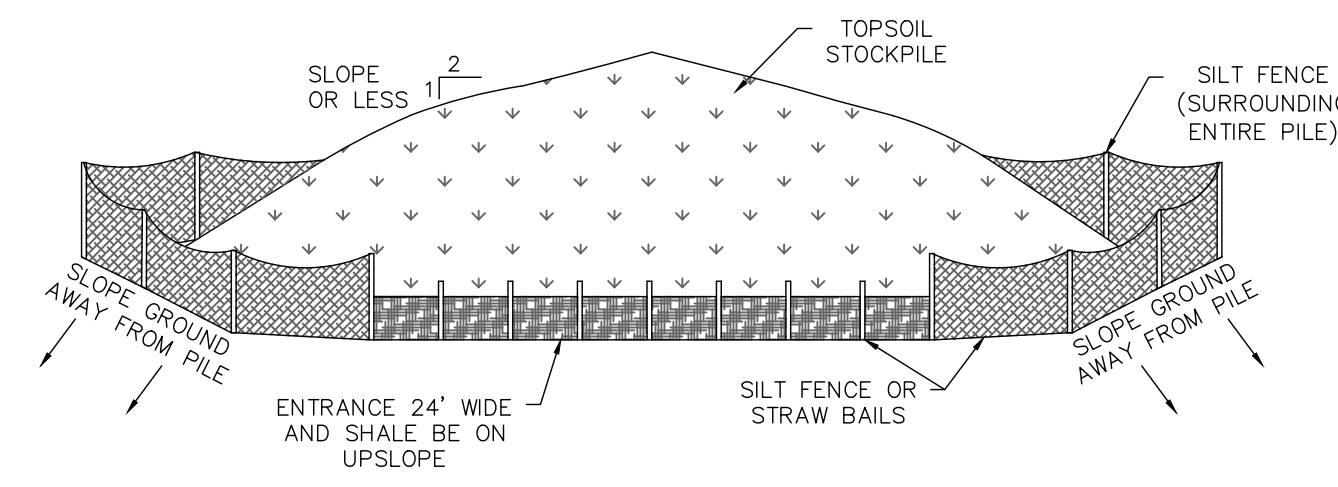

- NOTES:**
- SILT FENCE SHALL BE INSTALLED PER DETAIL.
  - IF THE STOCKPILE IS TO REMAIN FOR MORE THAN 14 DAYS, IT SHALL BE STABILIZED WITH SEED AND MULCH IMMEDIATELY AFTER COMPLETION OF STOCKPILING.
  - SILT FENCE SHALL BE INSPECTED WEEKLY AND SEDIMENT TRAPPED BY THE FENCING SHALL BE REMOVED OF AS NECESSARY.
  - SILT FENCE SHALL REMAIN IN PLACE UNTIL THE ENTIRE PILE HAS BEEN ELIMINATED.
  - AREA CHOSEN FOR STOCKPILING OPERATIONS SHALL BE DRY AND STABLE.

4  
503 TEMPORARY TOPSOIL STOCKPILE DETAIL  
NOT TO SCALE

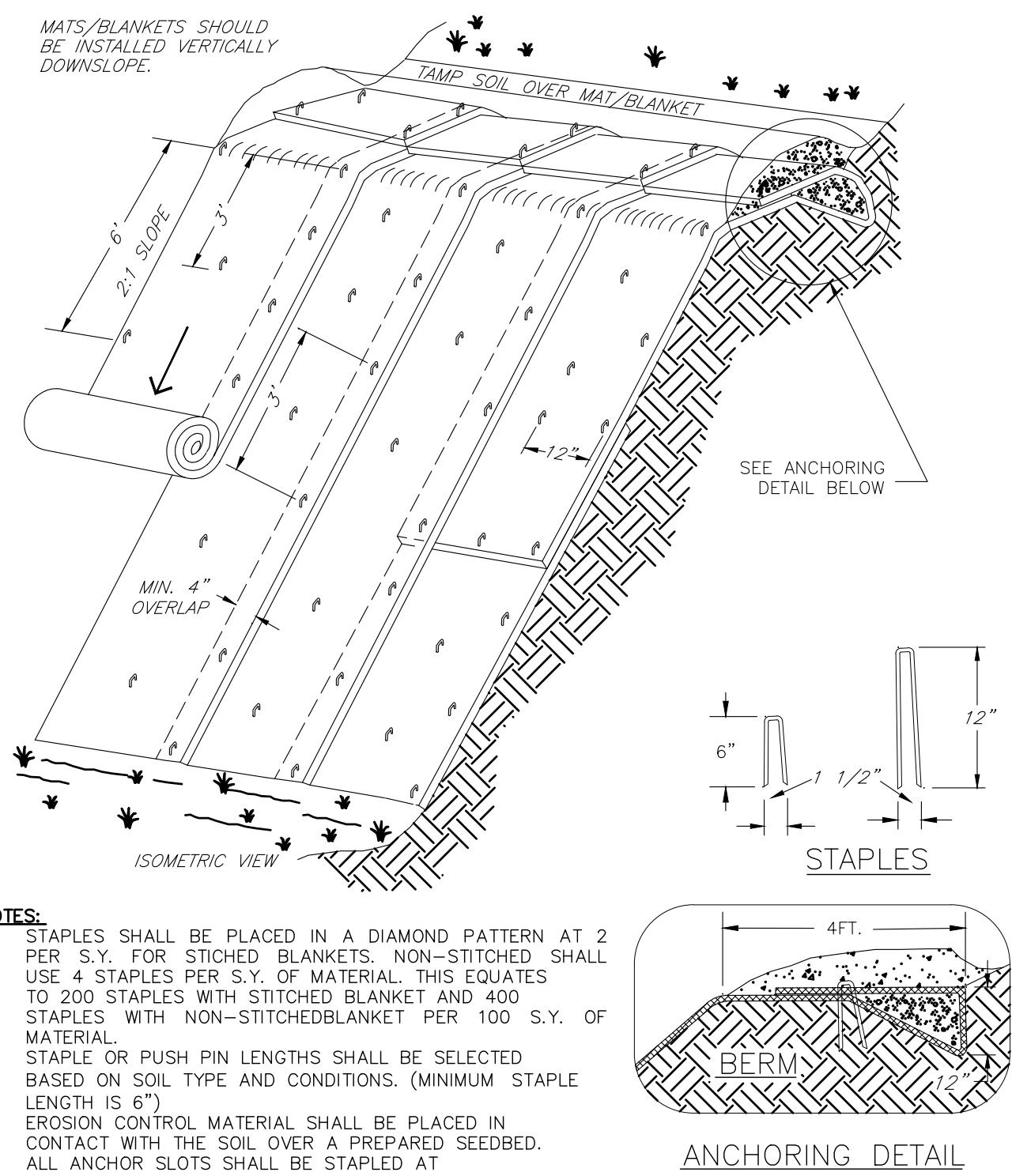

- NOTES:**
- STAPLES SHALL BE PLACED IN A DIAMOND PATTERN AT 2 PER S.Y. FOR STICED BLANKETS. NON-STITCHED SHALL USE 4 STAPLES PER S.Y. OF MATERIAL. THIS EQUATES TO 200 STAPLES WITH STITCHED BLANKET AND 400 STAPLES WITH NON-STITCHED BLANKET PER 100 S.Y. OF MATERIAL.
  - STAPLE OR PUSH PIN LENGTHS SHALL BE SELECTED BASED ON SOIL TYPE AND CONDITIONS. (MINIMUM STAPLE LENGTH IS 6")
  - EROSION CONTROL MATERIAL SHALL BE PLACED IN CONTACT WITH THE SOIL OVER A PREPARED SEEDBED.
  - ALL ANCHOR SLOTS SHALL BE STAPLED AT APPROXIMATELY 12" INTERVALS.

5  
503 EROSION CONTROL BLANKET INSTALLATION DETAIL  
NOT TO SCALE

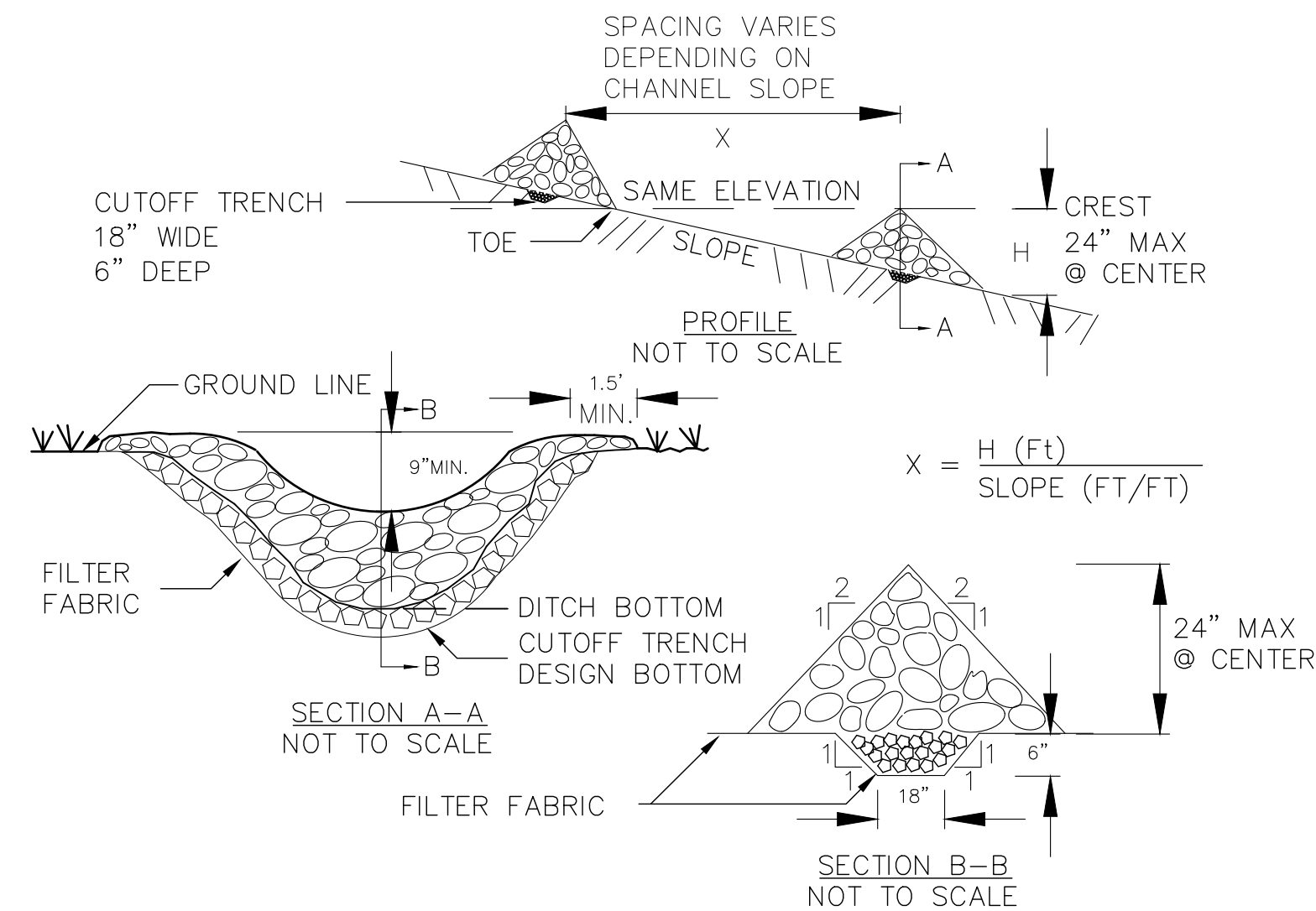

- NOTES:**
- STONE WILL BE PLACED ON A FILTER FABRIC FOUNDATION TO THE LINES, GRADES AND LOCATIONS SHOWN IN THE PLAN.
  - SET SPACING OF CHECK DAMS TO ASSUME THAT THE ELEVATIONS OF THE CREST OF THE DOWNSTREAM DAM IS AT THE SAME ELEVATION OF THE TOE OF THE UPSTREAM DAM.
  - EXTEND THE STONE A MINIMUM OF 1.5 FEET BEYOND THE DITCH BANKS TO PREVENT CUTTING AROUND THE DAM.
  - PROTECT THE CHANNEL DOWNSTREAM OF THE LOWEST CHECK DAM FROM SCOUR AND EROSION WITH STONE OR LINER AS APPROPRIATE.
  - ENSURE THAT CHANNEL APPURTENANCES SUCH AS CULVERT ENTRANCES BELOW CHECK DAMS ARE NOT SUBJECT TO DAMAGE OR BLOCKAGE FROM DISPLACED STONE. MAXIMUM DRAINAGE AREA 2 ACRES.

6  
503 CHECK DAM DETAIL  
NOT TO SCALE

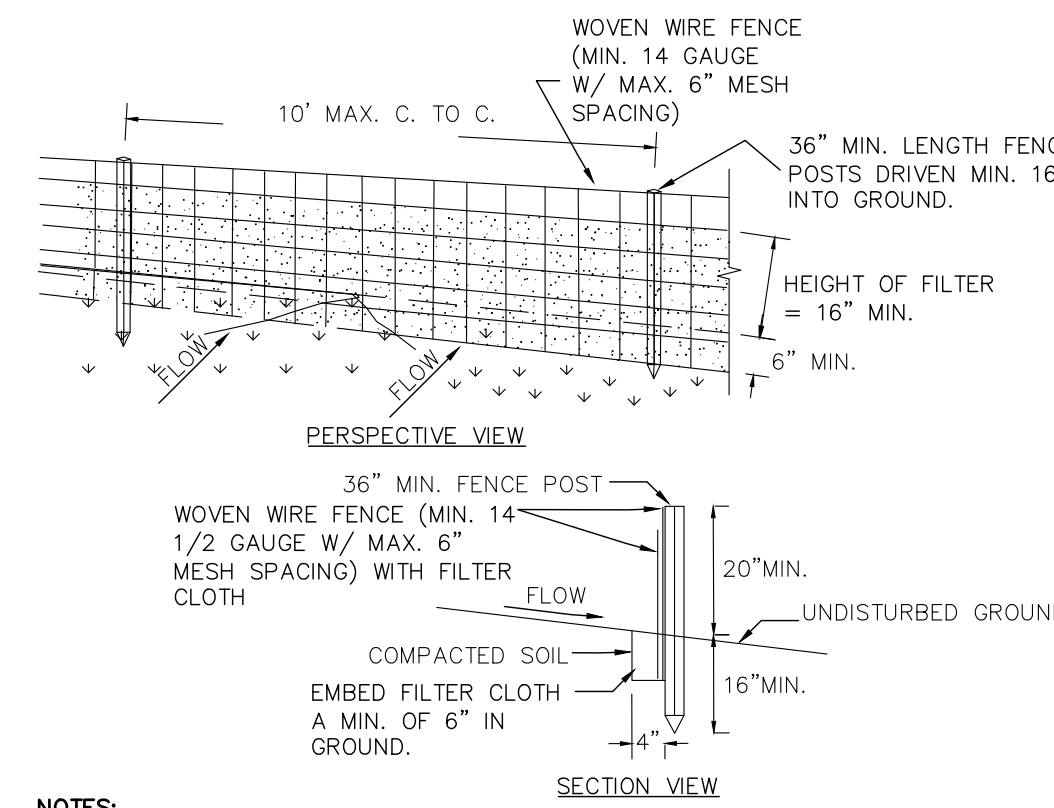

- NOTES:**
- WOVEN WIRE FENCE TO BE FASTENED SECURELY TO FENCE POSTS WITH WIRE TIES OR STAPLES. POSTS SHALL BE STEEL EITHER "T" OR "U" TYPE OR HARDWOOD.
  - FILTER CLOTH TO BE TO BE FASTENED SECURELY TO WOVEN WIRE FENCE WITH TIES SPACED EVERY 24" AT TOP AND MID SECTION. FENCE SHALL BE WOVEN WIRE, 6" MAXIMUM MESH OPENING.
  - WHEN TWO SECTIONS OF FILTER CLOTH ADJOIN EACH OTHER THEY SHALL BE OVERLAPPED BY SIX INCHES AND FOLDED. FILTER CLOTH SHALL BE EITHER FILTER X, MIRAFI 100X, STABILINKA T140N, OR APPROVED EQUIVALENT.
  - PREFABRICATED UNITS SHALL BE GEOTAF, ENVIROFENCE, OR APPROVED EQUIVALENT.
  - MAINTENANCE SHALL BE PERFORMED AS NEEDED AND MATERIAL REMOVED WHEN "BULGES" DEVELOP IN THE SILT FENCE.

7  
503 SILT FENCE DETAIL  
NOT TO SCALE

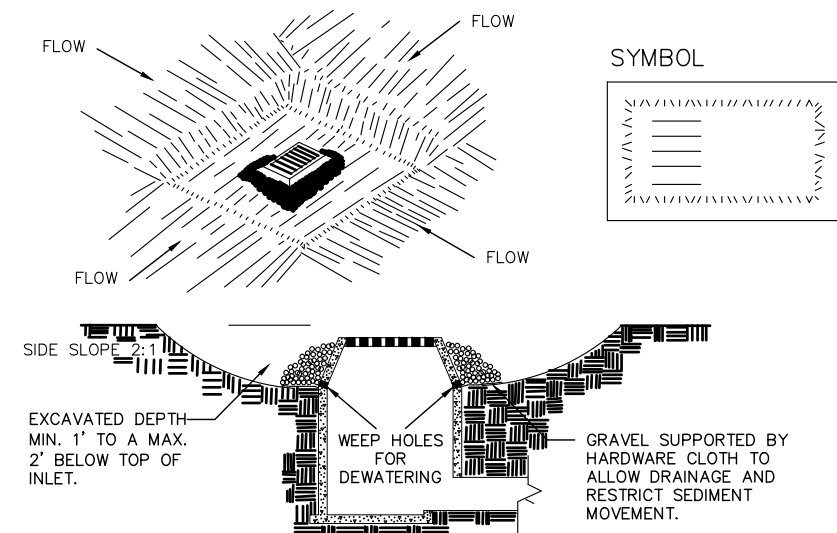

- NOTES:**
- CLEAR THE AREA OF ALL DEBRIS THAT WILL HINDER EXCAVATION.
  - GRADE APPROACH TO THE INLET UNIFORMLY AROUND THE BASIN.
  - WEEP HOLES SHALL BE PROTECTED BY GRAVEL.
  - UPON STABILIZATION OF CONTRIBUTING DRAINAGE AREA, SEAL WEEP HOLES, FILL EXCAVATION WITH STABLE SOIL TO FINAL GRADE, COMPACT IT PROPERLY AND STABILIZE WITH PERMANENT SEEDING. MAXIMUM DRAINAGE AREA 1 ACRE

8  
503 DROP INLET PROTECTION DETAIL  
NOT TO SCALE

No.	Revision Description	Date

PRIOR TO ANY EARTH DISTURBANCE THE CONTRACTOR SHALL CALL IN A TICKET TO DIG SAFE NY AND OBTAIN A CLEAR TO DIG

IT IS A VIOLATION OF SECTION 7209 OF THE NYS EDUCATION LAW FOR ANY PERSON TO ALTER ANY ITEM ON THIS PLAN IN ANY WAY UNLESS HE/SHE IS ACTING UNDER THE DIRECT SUPERVISION OF A PROFESSIONAL ENGINEER.

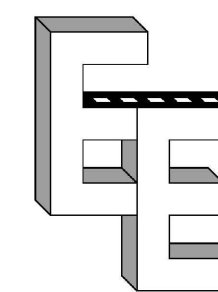

EMPIRE ENGINEERING, PLLC  
1900 DUANESBURG ROAD  
DUANESBURG, NY 12056  
PH: (518) 858-4117  
EMAIL: CLONGO@EMPIREENG.NET

PROJECT  
DAIM LOGISTICS, INC.  
128 PARK DRIVE  
GLEN PARK  
FULTONVILLE, NY 12072

Title  
E&S&C DETAILS

Date	10/21/2021	Sheet	C503
Scale	AS SHOWN	Sheet 5 of 5	